

SECTION VIEW

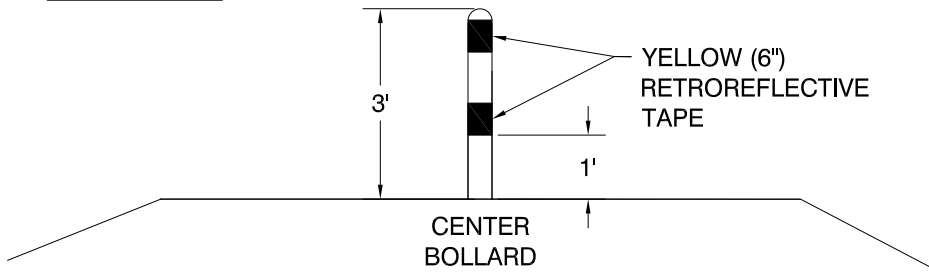

**MUTCD Section 9C.101(CA) Barrier Posts on Class I Bikeways**

**Support:** Before a decision is made to install barrier posts, consideration needs to be given to the implementation of other remedial measures, such as Bike Path Exclusion (R44A(CA)) signs (see Section 9B.08) and/or redesigning the path entry so that motorists do not confuse it with vehicle access.

**Guidance:** Such devices should be used only where extreme problems are encountered.

**Oakland Standard:** Removable bollards shall have a mount point that is flush with the travel surface.

PLAN VIEW

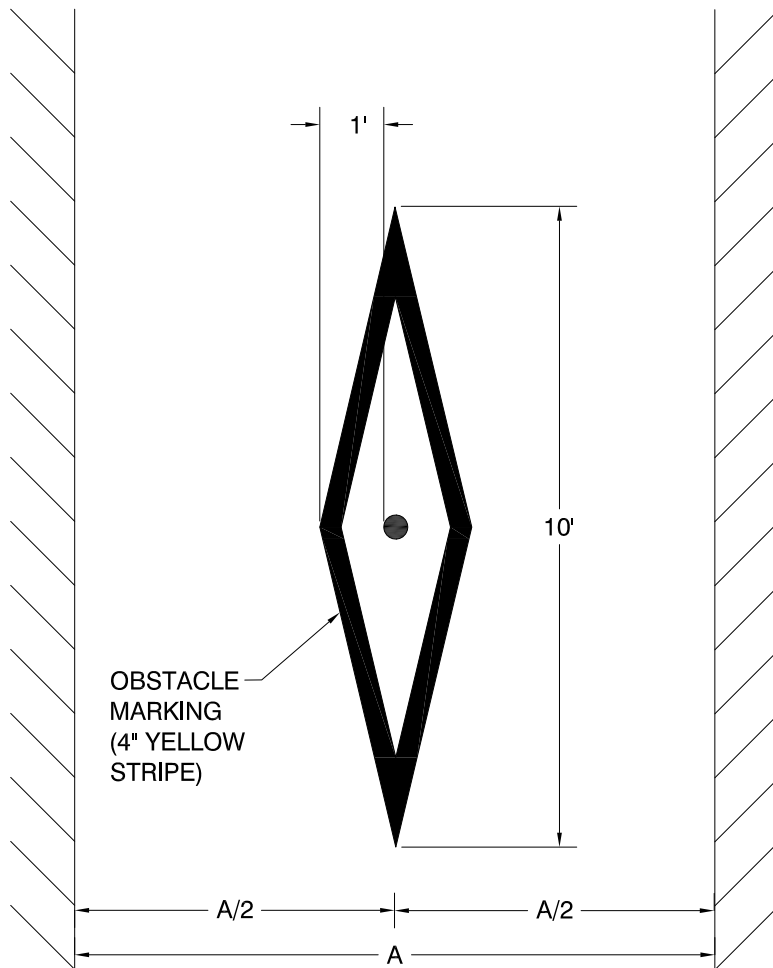

NOT TO SCALE



**CITY OF OAKLAND**

DEPARTMENT OF TRANSPORTATION | SAFE STREETS DIVISION  
BICYCLE & PEDESTRIAN PROGRAM  
250 FRANK H. OGAWA PLAZA, SUITE 4314 \* OAKLAND CA, 94612  
EMAIL: [blkeped@oaklandca.gov](mailto:blkeped@oaklandca.gov)

**BOLLARD PLACEMENT  
AND MARKINGS:  
CENTER BOLLARD**

**BICYCLE PATH DETAILS**

SCALE: NTS

DWG. NO.

DATE: MAR 2021

**BP-1**