

	<p>Wooden utility pole in public right-of-way adjacent to:</p> <ol style="list-style-type: none"> 3a) Case no. PLN18506 1900 101st Ave (APN: 047 -5502-020-00) General Plan: Detached Unit Residential Zoning: RD-1 Council District: 7 Submittal date: 11/26/18 3b) Case no. PLN18507 1607 Church St (APN: 039 -3251-031-00) General Plan: Detached Unit Residential Zoning: RD-1 Council District: 6 Submittal date: 11/26/18 <p style="text-align: right;"><i>(See map on reverse)</i></p>
Proposal:	To consider requests for two (2) applications to install a new “small cell site” Macro Telecommunications Facility on a JPA wooden utility pole by attaching antenna and equipment.
Applicant / Phone Number:	Ms. Ari Gibanov / Nexius Solutions (916) 910-5264
Owner:	Extenet, et al.
Planning Permit Required:	Regular Design Review with additional findings for Macro Telecommunications Facility
Environmental Determination:	Exempt, Section 15301 of the State CEQA Guidelines: Existing Facilities; Exempt, Section 15302: Replacement or Reconstruction; Exempt, Section 15303: New Construction of Small Structures; Section 15183: Projects Consistent with a Community Plan, General Plan or Zoning
Historic Status:	Non-historic property
Action to be Taken:	Approve with Conditions
Finality of Decision:	<i>Appealable to City Council within 10 days</i>
For Further Information:	Contact case planner Aubrey Rose AICP at (510) 238-2071 or arose@oaklandca.gov

EXECUTIVE SUMMARY

The applicant requests Planning Commission approval of two (2) applications to establish a “small cell site” Macro Telecommunications Facility on an existing wooden utility pole located in the public right-of-way (sidewalk) in a residential neighborhood. The project involves attaching a shrouded antenna and equipment to a utility pole, as described in the submitted plans, to enhance wireless service in the area.

Regular Design Review is required for the installation of a new Macro Telecommunications Facility in a residential zone, decided by the Planning Commission. The antenna shroud and associated equipment would be painted grey or brown to match the pole and/or other utilities located on the pole. As a result, the proposed telecommunication facility is an appropriate location and would not significantly increase negative visual impacts to adjacent properties including residences. The applications meets all the required findings for approval of these two (2) small cell sites.

TELECOMMUNICATIONS BACKGROUND

Limitations on Local Government Zoning Authority under the Telecommunications Act of 1996

Section 704 of the Telecommunications Act of 1996 (TCA) provides federal standards for the siting of "Personal Wireless Services Facilities." "Personal Wireless Services" include all commercial mobile services (including personal communications services (PCS), cellular radio mobile services, and paging); unlicensed wireless services; and common carrier wireless exchange access services. Under Section 704, local zoning authority over personal wireless services is preserved such that the FCC is prevented from preempting local land use decisions; however, local government zoning decisions are still restricted by several provisions of federal law. Specifically:

- Under Section 253 of the TCA, no state or local regulation or other legal requirement can prohibit or have the effect of prohibiting the ability of any entity to provide any interstate or intrastate telecommunications service.
- Further, Section 704 of the TCA imposes limitations on what local and state governments can do. Section 704 prohibits any state and local government action which unreasonably discriminates among personal wireless providers. Local governments must ensure that its wireless ordinance does not contain requirements in the form of regulatory terms or fees which may have the "effect" of prohibiting the placement, construction, or modification of personal wireless services.
- Section 704 also preempts any local zoning regulation purporting to regulate the placement, construction and modification of personal wireless service facilities on the basis, either directly or indirectly, on the environmental effects of radio frequency emissions (RF) of such facilities, which otherwise comply with Federal Communications Commission (FCC) standards in this regard. (See 47 U.S.C. Section 332(c)(7)(B)(iv) (1996)). This means that local authorities may not regulate the siting or construction of personal wireless facilities based on RF standards that are more stringent than those promulgated by the FCC.
- Section 704 mandates that local governments act upon personal wireless service facility siting applications to place, construct, or modify a facility within a reasonable time (See 47 U.S.C.332(c)(7)(B)(ii) and FCC Shot Clock ruling setting forth "reasonable time" standards for applications deemed complete).
- Section 704 also mandates that the FCC provide technical support to local governments in order to encourage them to make property, rights-of-way, and easements under their jurisdiction available for the placement of new spectrum-based telecommunications services. This proceeding is currently at the comment stage.

For more information on the FCC's jurisdiction in this area, consult the following:
Competition & Infrastructure Policy Division (CIPD) of the Wireless Telecommunications Bureau, main division number: (202) 418-1310. <https://www.fcc.gov/general/competition-infrastructure-policy-division-wireless-telecommunications-bureau>

PROPERTY DESCRIPTION

1. 3a) Case no. PLN18506; 1900 101st Avenue

The site consists of an existing 38'-7" tall wooden utility pole within the public right-of-way (sidewalk) hosting wires and containing a City street light. The pole is along Birch Street towards the corner of 101st Avenue. The corner property contains a one-story single-family home facing 101st Avenue with no large windows facing Birch Street. The neighborhood primarily consists of one and two-story single-family homes.

2. 3b) Case no. PLN18507; 1607 Church Street

The site consists of an existing 39'-8" tall wooden utility pole within the public right-of-way (sidewalk) hosting wires and containing a City street light. The pole fronts a one-story single-family home in a neighborhood primarily consisting of one and two-story single-family homes.

PROJECT DESCRIPTION

As shown in **Attachment C** for **Case no. PLN18506** and in **Attachment D** for **Case no. PLN18507**, the project applicant proposes the following:

1. 3a) Case no. PLN18506; 1900 101st Avenue

- Install by side-mounting one antenna within an antenna shroud at a height of up to 23'-7";
- Install equipment at a height of up to 18-feet above grade; and,
- Paint the proposed antennas and associated equipment grey to match the pole and/or other utilities located on the pole.

2. 3b) Case no. PLN18507; 1607 Church Street

- Install by top-mounting one antenna within an antenna shroud at a height of up to 44'-3";
- Install equipment at a height up to 18-feet above grade; and,
- Paint the proposed antennas and associated equipment grey to match the pole and/or other utilities located on the pole.

No portion of the telecommunication facilities would be located at grade. The proposed antenna and associated equipment would not be accessible to the public.

SIMILAR CASES

Records show that the Planning Commission has approved over 70 Macro Telecommunications Facilities requiring Design Review throughout the City since 2016.

GENERAL PLAN ANALYSIS

Both sites are in the Detached Unit Housing Type area of the General Plan's Land Use and Transportation Element (LUTE). The intent of the area is: "to create, maintain, and enhance residential areas characterized by detached, single unit structures." The proposed telecommunication facilities would be mounted on existing wooden utility poles within the City of Oakland public right-of-way. The proposed unmanned wireless telecommunication facility would not adversely affect the characteristics of the neighborhood.

ZONING ANALYSIS

The proposed sites are located in the RD-1 Detached Unit Residential Zone. Macro Telecommunications Facilities on JPA wooden utility poles require a Regular Design Review permit; this is decided by the Planning Commission for a site within a Residential Zone. Special findings are also required for Design Review approval to ensure that the facility is concealed to the greatest extent possible. The project design is discussed later in this report, and the required findings for Regular Design Review are listed and included in staff's evaluation letter in this report.

ENVIRONMENTAL DETERMINATION

The California Environmental Quality Act (CEQA) Guidelines list the projects that qualify as categorical exemptions from environmental review. The proposed project is categorically exempt from the environmental review requirements pursuant to Section 15301, minor additions and alterations to an existing utility pole; Section 15303, new construction or conversion of small structures, and Section 15183, projects consistent with a community plan, general plan or zoning.

KEY ISSUES AND IMPACTS

The proposal to establish a Macro Telecommunications Facility is subject to the following Planning Code development standards, which are followed by staff's analysis in relation to this application:

17.128.070 Macro Telecommunications Facilities.

A. General Development Standards for Macro Telecommunications Facilities.

1. The Macro Facilities shall be located on existing buildings, poles or other existing support structures, or shall be post mounted.

The projects involve attachment to existing utility poles hosting power lines and a City street light.

2. The equipment shelter or cabinet must be concealed from public view or made compatible with the architecture of the surrounding structures or placed underground. The shelter or cabinet must be regularly maintained.

Recommended conditions of approval require painting and texturizing the antenna, equipment, and all components to match the appearance of the utility poles and appurtenances.

3. Macro Facilities may exceed the height limitation specified for all zones but may not exceed fifteen (15) feet above the roof line or parapet. Placement of an antenna on a nonconforming structure shall not be considered to be an expansion of the nonconforming structure.

This standard is inapplicable because the proposal does not involve attachment to a roofed structure.

4. Ground post mounted Macro Facilities must not exceed seventeen (17) feet to the top of the antenna.

This standard is inapplicable because the proposal does not involve ground post mounting.

5. The applicant shall submit written documentation demonstrating that the emissions from the proposed project are within the limits set by the Federal Communications Commission.

This standard is met by the proposals; satisfactory emission reports have been submitted and are attached to this report (Attachments C and D).

17.128.110 Site location preferences.

New wireless facilities shall generally be located on the following properties or facilities in order of preference:

- A. Co-located on an existing structure or facility with existing wireless antennas.**
- B. City-owned properties or other public or quasi-public facilities.**
- C. Existing commercial or industrial structures in Nonresidential Zones (excluding all HBX Zones and the D-CE-3 and D-CE-4 Zones).**
- D. Existing commercial or industrial structures in Residential Zones, HBX Zones, or the DCE-3 or D-CE-4 Zones.**
- E. Other Nonresidential uses in Residential Zones, HBX Zones, or the D-CE-3 or D-CE-4 Zones.**
- F. Residential uses in Nonresidential Zones (excluding all HBX Zones and the D-CE-3 and D-CE-4 Zones).**
- G. Residential uses in Residential Zones, HBX Zones, or the D-CE-3 or D-CE-4 Zones.**

Site alternatives analyses are not required because the proposals conform to 'B' as they would be located on quasi-public facilities (utility poles with power lines). Nonetheless, the applicant has submitted analyses which are attached to this report (Attachments C and D). The projects are located in an area with existing residential structures. The project applicant considered alternative sites on other utility poles in this area but none of these sites are as desirable from a service coverage perspective or from an aesthetics perspective to minimize visual impacts. The proposed project is in an underserved area. Staff has reviewed the applicant's alternative sites analyses and determined that the sites selected conforms to the telecommunications facility regulations requirements.

17.128.120 Site design preferences.

New wireless facilities shall generally be designed in the following order of preference:

- A. Building or structure mounted antennas completely concealed from view.**
- B. Building or structure mounted antennas set back from roof edge, not visible from public right-of way.**
- C. Building or structure mounted antennas below roof line (facade mount, pole mount) visible from public right-of-way, painted to match existing structure.**
- D. Building or structure mounted antennas above roof line visible from public right-of-way.**
- E. Monopoles.**
- F. Towers.**

Facilities designed to meet an A or B ranked preference do not require a site design alternatives analysis. Facilities designed to meet a C through F ranked preference, inclusive, must submit a site design alternatives analysis as part of the required application materials. A site design alternatives analysis shall, at a minimum, consist of: a. Written evidence indicating why each such higher preference design alternative cannot be used. Such evidence shall be in sufficient detail that independent verification could be obtained if required by the City of Oakland Zoning Manager. Evidence should indicate if the reason an alternative was rejected was technical (e.g. incorrect height, interference from existing RF sources, inability to cover required area) or for other concerns (e.g. inability to provide utilities, construction or structural impediments).

The proposal most closely conforms to 'C' (Building or structure mounted antennas below roof line (facade mount, pole mount) visible from public right-of-way, painted to match existing structure.), and the applicant has submitted a satisfactory site design alternatives analysis (**Attachments C and D**).

17.128.130 Radio Frequency Emissions Standards.

The applicant for all wireless facilities, including requests for modifications to existing facilities, shall submit the following verifications:

- a. With the initial application, a RF emissions report, prepared by a licensed professional engineer or other expert, indicating that the proposed site will operate within the current acceptable thresholds as established by the Federal government or any such agency who may be subsequently authorized to establish such standards.
- b. Prior to commencement of construction, a RF emissions report indicating the baseline RF emissions condition at the proposed site.
- c. Prior to final building permit sign off, an RF emissions report indicating that the site is actually operating within the acceptable thresholds as established by the Federal government or any such agency who may be subsequently authorized to establish such standards.

In the analyses prepared by Hammett & Edison, Inc. (**Attachments C and D**), the proposed project was evaluated for compliance with appropriate guidelines limiting human exposure to radio frequency electromagnetic fields. According to the report, the project would comply with the prevailing standards for limiting public exposure to radio frequency energy, and therefore, the proposed site would operate within the current acceptable thresholds as established by the Federal government or any such agency that may be subsequently authorized to establish such standards. Additionally, the Planning Code required that, prior to the final building permit sign off, the applicant submit a certified RF emissions report stating that the facility is operating within acceptable thresholds established by the regulatory Federal agency.

CONCLUSION

As conditioned, the proposed site design would not be situated on an historic or decorative pole or structure, would not create a view obstruction, and would not negatively impact a view from a primary living space such as a living room or bedroom window. The project meets all the required findings for approval and would provide an essential telecommunication service to the community and the City of Oakland at large. It would also be available to emergency services such as police, fire department and emergency response teams. Staff believes that the proposal is designed to meet the established zoning and telecommunication regulations and recommends supporting the Regular Design Review application.

RECOMMENDATIONS:

1. Affirm staff's environmental determination.
2. Approve the Regular Design Review subject to the attached Findings and Conditions of Approval.

Prepared by:

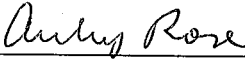

AUBREY ROSE, AICP
Planner III

Reviewed by:

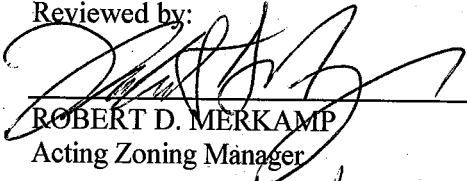

ROBERT D. MERKAMP
Acting Zoning Manager

Approved for forwarding to the Planning Commission:

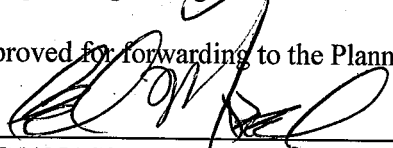

ED MANASSE, Interim Deputy Director
Planning Bureau

ATTACHMENTS:

A. Findings

B. Conditions of Approval

Plans / Photo-Simulations / Site Analyses / RF Report:

C. 3a) Case no. PLN18506; 1900 101st Avenue

D. 3b) Case no. PLN18507; 1607 Church Street

E. Correspondence

ATTACHMENT A: FINDINGS

This proposal meets the required findings under Residential Design Review Criteria for Nonresidential Facilities (OMC Sec. 17.136.050(B)) and Telecommunications Regulations/Design Review Criteria for Macro Telecommunications Facilities (OMC Sec. 17.128.070(B)), as set forth below. Required findings are shown in **bold type**; explanations as to why these findings can be made are in normal type.

REGULAR DESIGN REVIEW CRITERIA FOR NON-RESIDENTIAL FACILITIES (OMC SEC. 17.136.050(B))

1. That the proposal will help achieve or maintain a group of facilities which are well related to one another and which, when taken together, will result in a well-composed design, with consideration given to site, landscape, bulk, height, arrangement, texture, materials, colors, and appurtenances; the relation of these factors to other facilities in the vicinity; and the relation of the proposal to the total setting as seen from key points in the surrounding area. Only elements of design which have some significant relationship to outside appearance shall be considered, except as otherwise provided in Section 17.136.060;

The attachment of a small antenna and equipment to non-historic utility poles, as conditioned including painted and texturized to match the poles and power line posts in appearance for camouflaging will be the least intrusive design. The proposal, as conditioned, will not create a view obstruction, be directly adjacent to a primary living space such as a living room or bedroom window, or be located on an historic structure.

2. That the proposed design will be of a quality and character which harmonizes with, and serves to protect the value of, private and public investments in the area;

The proposal will enhance essential services in an urbanized neighborhood.

3. That the proposed design conforms in all significant respects with the Oakland General Plan and with any applicable design review guidelines or criteria, district plan, or development control map which have been adopted by the Planning Commission or City Council.

Both sites are in the Detached Unit Housing Type area of the General Plan's Land Use and Transportation Element (LUTE). The intent of the area is: "to create, maintain, and enhance residential areas characterized by detached, single unit structures." The proposed telecommunication facilities would be mounted on existing wooden utility poles within the City of Oakland public right-of-way. The proposed unmanned wireless telecommunication facility would not adversely affect the characteristics of the neighborhood.

TELECOMMUNICATIONS REGULATIONS/DESIGN REVIEW CRITERIA FOR MACRO TELECOMMUNICATIONS FACILITIES (OMC SEC. 17.128.070(B))

1. Antennas should be painted and/or textured to match the existing structure.

The antennas will be painted and texturized to match the poles in appearance for camouflaging will be the least intrusive design, as required by conditions of approval.

2. Antennas mounted on architecturally significant structures or significant architectural detail of the building should be covered by appropriate casings which are manufactured to match existing architectural features found on the building.

This finding is inapplicable because the antennas will not be mounted onto an architecturally significant structure but to a wooden utility pole.

3. Where feasible, antennas can be placed directly above, below or incorporated with vertical design elements of a building to help in camouflaging.

The antennas will be located parallel to the host utility pole below posts hosting power lines.

4. Equipment shelters or cabinets shall be screened from the public view by using landscaping, or materials and colors consistent with surrounding backdrop or placed underground or inside existing facilities or behind screening fences.

Conditions of approval require painting and texturing to match the pole in appearance for camouflaging.

5. Equipment shelters or cabinets shall be consistent with the general character of the area.

Equipment will be attached to the utility pole with an unobtrusive design.

6. For antennas attached to the roof, maintain a 1:1 ratio (example: ten (10) feet high antenna requires ten (10) feet setback from facade) for equipment setback; screen the antennas to match existing air conditioning units, stairs, or elevator towers; avoid placing roof mounted antennas in direct line with significant view corridors.

This finding is inapplicable because the antennas will be attached to a pole and not to a roofed structure.

7. That all reasonable means of reducing public access to the antennas and equipment has been made, including, but not limited to, placement in or on buildings or structures, fencing, anti-climbing measures and anti-tampering devices.

The minimal clearance to the facility will be 7'-4".

Attachment B: Conditions of Approval

1. Approved Use

The project shall be constructed and operated in accordance with the authorized use as described in the approved application materials, **staff report** and the approved plans **dated September 11 – October 12, 2018 and submitted November 26, 2018**, as amended by the following conditions of approval and mitigation measures, if applicable (“Conditions of Approval” or “Conditions”).

Two (2) approvals to install a new “small cell site” Monopole Telecommunications Facilities on an existing wooden utility pole in the public right-of-way (sidewalk) by attaching a shrouded antenna and equipment adjacent to:

E. 3a) Case no. PLN18506; 1900 101st Avenue

F. 3b) Case no. PLN18507; 1607 Church Street

2. Effective Date, Expiration, Extensions and Extinguishment

This Approval shall become effective immediately, unless the Approval is appealable, in which case the Approval shall become effective in ten calendar days unless an appeal is filed. Unless a different termination date is prescribed, this Approval shall expire **two calendar years** from the Approval date, or from the date of the final decision in the event of an appeal, unless within such period all necessary permits for construction or alteration have been issued, or the authorized activities have commenced in the case of a permit not involving construction or alteration. Upon written request and payment of appropriate fees submitted no later than the expiration date of this Approval, the Director of City Planning or designee may grant a one-year extension of this date, with additional extensions subject to approval by the approving body. Expiration of any necessary building permit or other construction-related permit for this project may invalidate this Approval if said Approval has also expired. If litigation is filed challenging this Approval, or its implementation, then the time period stated above for obtaining necessary permits for construction or alteration and/or commencement of authorized activities is automatically extended for the duration of the litigation.

3. Compliance with Other Requirements

The project applicant shall comply with all other applicable federal, state, regional, and local laws/codes, requirements, regulations, and guidelines, including but not limited to those imposed by the City’s Bureau of Building, Fire Marshal, and Public Works Department. Compliance with other applicable requirements may require changes to the approved use and/or plans. These changes shall be processed in accordance with the procedures contained in Condition #4.

4. Minor and Major Changes

- a. Minor changes to the approved project, plans, Conditions, facilities, or use may be approved administratively by the Director of City Planning.
- b. Major changes to the approved project, plans, Conditions, facilities, or use shall be reviewed by the Director of City Planning to determine whether such changes require submittal and approval of a revision to the Approval by the original approving body or a new independent permit/approval. Major revisions shall be reviewed in accordance with the procedures required for the original permit/approval. A new independent permit/approval shall be reviewed in accordance with the procedures required for the new permit/approval.

5. Compliance with Conditions of Approval

- a. The project applicant and property owner, including successors, (collectively referred to hereafter as the "project applicant" or "applicant") shall be responsible for compliance with all the Conditions of Approval and any recommendations contained in any submitted and approved technical report at his/her sole cost and expense, subject to review and approval by the City of Oakland.
- b. The City of Oakland reserves the right at any time during construction to require certification by a licensed professional at the project applicant's expense that the as-built project conforms to all applicable requirements, including but not limited to, approved maximum heights and minimum setbacks. Failure to construct the project in accordance with the Approval may result in remedial reconstruction, permit revocation, permit modification, stop work, permit suspension, or other corrective action.
- c. Violation of any term, Condition, or project description relating to the Approval is unlawful, prohibited, and a violation of the Oakland Municipal Code. The City of Oakland reserves the right to initiate civil and/or criminal enforcement and/or abatement proceedings, or after notice and public hearing, to revoke the Approval or alter these Conditions if it is found that there is violation of any of the Conditions or the provisions of the Planning Code or Municipal Code, or the project operates as or causes a public nuisance. This provision is not intended to, nor does it, limit in any manner whatsoever the ability of the City to take appropriate enforcement actions. The project applicant shall be responsible for paying fees in accordance with the City's Master Fee Schedule for inspections conducted by the City or a City-designated third-party to investigate alleged violations of the Approval or Conditions.

6. Signed Copy of the Approval/Conditions

A copy of the Approval letter and Conditions shall be signed by the project applicant, attached to each set of permit plans submitted to the appropriate City agency for the project, and made available for review at the project job site at all times.

7. Blight/Nuisances

The project site shall be kept in a blight/nuisance-free condition. Any existing blight or nuisance shall be abated within 60 days of approval, unless an earlier date is specified elsewhere.

8. Indemnification

- a. To the maximum extent permitted by law, the project applicant shall defend (with counsel acceptable to the City), indemnify, and hold harmless the City of Oakland, the Oakland City Council, the Oakland Redevelopment Successor Agency, the Oakland City Planning Commission, and their respective agents, officers, employees, and volunteers (hereafter collectively called "City") from any liability, damages, claim, judgment, loss (direct or indirect), action, causes of action, or proceeding (including legal costs, attorneys' fees, expert witness or consultant fees, City Attorney or staff time, expenses or costs) (collectively called "Action") against the City to attack, set aside, void or annul this Approval or implementation of this Approval. The City may elect, in its sole discretion, to participate in the defense of said Action and the project applicant shall reimburse the City for its reasonable legal costs and attorneys' fees.

- b. Within ten (10) calendar days of the filing of any Action as specified in subsection (a) above, the project applicant shall execute a Joint Defense Letter of Agreement with the City, acceptable to the Office of the City Attorney, which memorializes the above obligations. These obligations and the Joint Defense Letter of Agreement shall survive termination, extinguishment, or invalidation of the Approval. Failure to timely execute the Letter of Agreement does not relieve the project applicant of any of the obligations contained in this Condition or other requirements or Conditions of Approval that may be imposed by the City.

9. Severability

The Approval would not have been granted but for the applicability and validity of each and every one of the specified Conditions, and if one or more of such Conditions is found to be invalid by a court of competent jurisdiction this Approval would not have been granted without requiring other valid Conditions consistent with achieving the same purpose and intent of such Approval.

10. Job Site Plans

Ongoing throughout demolition, grading, and/or construction

At least one (1) copy of the stamped approved plans, along with the Approval Letter and Conditions of Approval, shall be available for review at the job site at all times.

11. Special Inspector/Inspections, Independent Technical Review, Project Coordination and Monitoring

The project applicant may be required to cover the full costs of independent third-party technical review and City monitoring and inspection, including without limitation, special inspector(s)/inspection(s) during times of extensive or specialized plan-check review or construction, and inspections of potential violations of the Conditions of Approval. The project applicant shall establish a deposit with the Bureau of Building, if directed by the Building Official, Director of City Planning, or designee, prior to the issuance of a construction-related permit and on an ongoing as-needed basis.

12. Public Improvements

The project applicant shall obtain all necessary permits/approvals, such as encroachment permits, obstruction permits, curb/gutter/sidewalk permits, and public improvement ("p-job") permits from the City for work in the public right-of-way, including but not limited to, streets, curbs, gutters, sidewalks, utilities, and fire hydrants. Prior to any work in the public right-of-way, the applicant shall submit plans for review and approval by the Bureau of Planning, the Bureau of Building, and other City departments as required. Public improvements shall be designed and installed to the satisfaction of the City.

13. Construction Days/Hours

Requirement: The project applicant shall comply with the following restrictions concerning construction days and hours:

- a. Construction activities are limited to between 7:00 a.m. and 7:00 p.m. Monday through Friday, except that pier drilling and/or other extreme noise generating activities greater than 90 dBA shall be limited to between 8:00 a.m. and 4:00 p.m.
- b. Construction activities are limited to between 9:00 a.m. and 5:00 p.m. on Saturday. In residential zones and within 300 feet of a residential zone, construction activities are allowed from 9:00 a.m. to 5:00 p.m. only within the interior of the building with the doors and windows closed. No pier drilling or other extreme noise generating activities greater than 90 dBA are allowed on Saturday.

c. No construction is allowed on Sunday or federal holidays.

Construction activities include, but are not limited to, truck idling, moving equipment (including trucks, elevators, etc.) or materials, deliveries, and construction meetings held on-site in a non-enclosed area.

Any construction activity proposed outside of the above days and hours for special activities (such as concrete pouring which may require more continuous amounts of time) shall be evaluated on a case-by-case basis by the City, with criteria including the urgency/emergency nature of the work, the proximity of residential or other sensitive uses, and a consideration of nearby residents'/occupants' preferences. The project applicant shall notify property owners and occupants located within 300 feet at least 14 calendar days prior to construction activity proposed outside of the above days/hours. When submitting a request to the City to allow construction activity outside of the above days/hours, the project applicant shall submit information concerning the type and duration of proposed construction activity and the draft public notice for City review and approval prior to distribution of the public notice.

When Required: During construction

Initial Approval: N/A

Monitoring/Inspection: Bureau of Building

PROJECT-SPECIFIC CONDITIONS

14. Emissions Report

Requirement: A RF emissions report shall be submitted to the Planning Bureau indicating that the site is actually operating within the acceptable thresholds as established by the Federal government or any such agency who may be subsequently authorized to establish such standards.

Requirement: Prior to a final inspection

When Required: Prior to final building permit inspection sign-off

Initial Approval: N/A

Monitoring/Inspection: N/A

15. Camouflage

Requirement: The antenna and equipment shall be painted, texturized, and maintained the same color and finish of the City light pole.

When Required: Prior to a final inspection

Initial Approval: N/A

Monitoring/Inspection: Bureau of Building

16. Operational

Requirement: Noise levels from the activity, property, or any mechanical equipment on site shall comply with the performance standards of Section 17.120 of the Oakland Planning Code and Section 8.18 of the Oakland Municipal Code. If noise levels exceed these standards, the activity causing the noise shall be abated until appropriate noise reduction measures have been installed and compliance verified by the Planning and Zoning Division and Building Services.

When Required: Ongoing

Initial Approval: N/A

Monitoring/Inspection: Bureau of Building

17. Graffiti Control

Requirement:

- a. During construction and operation of the project, the project applicant shall incorporate best management practices reasonably related to the control of graffiti and/or the mitigation of the impacts of graffiti. Such best management practices may include, without limitation:
- b. The project applicant shall remove graffiti by appropriate means within seventy-two (72) hours. Appropriate means include the following:
 - i. Removal through scrubbing, washing, sanding, and/or scraping (or similar method) without damaging the surface and without discharging wash water or cleaning detergents into the City storm drain system.
 - ii. For galvanized poles, covering with new paint to match the color of the surrounding surface.
 - iii. Replace pole numbers.

When Required: Ongoing

Initial Approval: N/A

Monitoring/Inspection: Bureau of Building

NW-CA-SANFRNMC-51177
SF90XS0X9-L
1900 101ST AVENUE (BIRCH
STREET FRONTAGE)
OAKLAND, CA 94603
 SITE TYPE: WOOD POLE IN PROW
 POLE REPLACEMENT: NO
 POWER: PG&E
 CARRIER: SPRINT

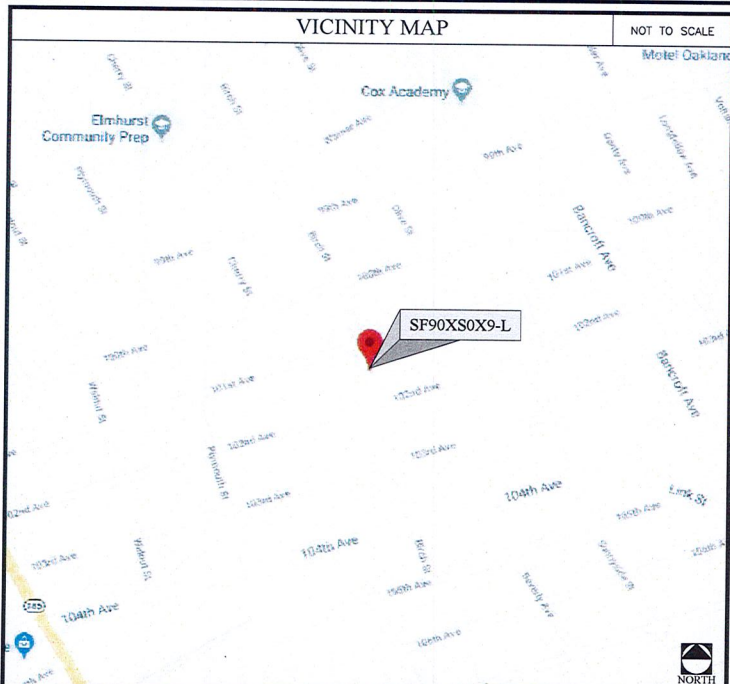
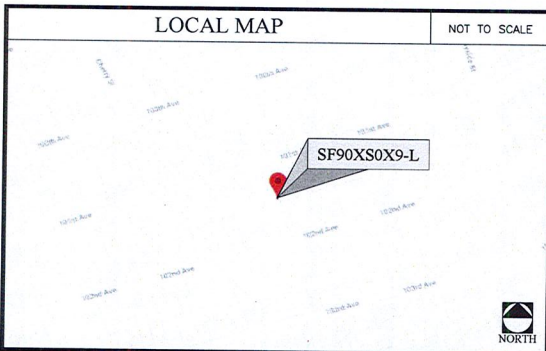

CODE COMPLIANCE

ALL WORK AND MATERIALS SHALL BE PERFORMED AND INSTALLED IN ACCORDANCE WITH THE CURRENT EDITIONS OF THE FOLLOWING CODES AS ADOPTED BY THE LOCAL GOVERNING AUTHORITIES (AS APPLICABLE). NOTHING IN THESE PLANS IS TO BE CONSTRUCTED TO PERMIT WORK NOT CONFORMING TO THESE CODES.

- 2015 INTERNATIONAL BUILDING CODE
- CALIFORNIA BUILDING STANDARDS CODE-2016
- CALIFORNIA GENERAL ORDER 95
- CALIFORNIA MECHANICAL CODE 2016
- CALIFORNIA PLUMBING CODE 2016
- CALIFORNIA ELECTRICAL CODE 2016
- CITY AND/OR COUNTY ORDINANCES
- 2012 INTERNATIONAL FIRE CODE

PROJECT DESCRIPTION

THESE DRAWINGS DEPICT THE INSTALLATION OF A WIRELESS TELECOMMUNICATIONS FACILITY IN THE PUBLIC RIGHT OF WAY. HARDWARE AND ANCILLARY EQUIPMENT TO BE INSTALLED AS DESCRIBED HEREIN.

GENERAL PROJECT NOTES

- PRIOR TO SUBMITTING A BID, THE CONTRACTOR SHALL FAMILIARIZE HIMSELF/HERSELF WITH THE SCOPE OF WORK AND ALL CONDITIONS AFFECTING THE NEW PROJECT.
- CONTRACTOR SHALL VERIFY ALL FIELD CONDITIONS AND DIMENSIONS OF THE JOB SITE AND CONFIRM THAT WORK AS INDICATED ON THESE CONSTRUCTION DOCUMENTS CAN BE ACCOMPLISHED AS SHOWN PRIOR TO COMMENCEMENT OF ANY WORK.
- ALL FIELD MODIFICATIONS BEFORE, DURING OR AFTER CONSTRUCTION SHALL BE APPROVED IN WRITING BY AN EXTENET SYSTEMS REPRESENTATIVE.
- INSTALL ALL EQUIPMENT AND MATERIALS PER THE MANUFACTURER'S RECOMMENDATIONS, UNLESS INDICATED OTHERWISE.
- NOTIFY EXTENET SYSTEMS, IN WRITING, OF ANY MAJOR DISCREPANCIES REGARDING THE CONTRACT DOCUMENTS, EXISTING CONDITIONS, AND DESIGN INTENT. THE CONTRACTOR SHALL BE RESPONSIBLE FOR OBTAINING CLARIFICATIONS FROM AN EXTENET SYSTEMS REPRESENTATIVE, AND ADJUSTING THE BID ACCORDINGLY.
- CONTRACTOR SHALL BE SOLELY RESPONSIBLE FOR ALL CONSTRUCTION MEANS, METHODS, TECHNIQUES, SEQUENCES AND PROCEDURES OF THE WORK UNDER THE CONTRACT.
- CONTRACTOR SHALL PROTECT ALL EXISTING IMPROVEMENTS AND FINISHES THAT ARE TO REMAIN. CONTRACTOR SHALL REPAIR ANY DAMAGE THAT MAY OCCUR DURING THE CONSTRUCTION TO THE SATISFACTION OF AN EXTENET SYSTEMS REPRESENTATIVE.
- CONTRACTOR PLANS TO ILLUSTRATE THE AS-BUILT CONDITION OF THE SITE, FOLLOWING THE FINAL INSPECTION BY EXTENET OR SPRINT. THE CONTRACTOR SHALL PROVIDE EXTENET SYSTEMS WITH ONE COPY OF ALL RED-LINED DRAWINGS.
- VERIFY ALL FINAL EQUIPMENT WITH AN EXTENET SYSTEMS REPRESENTATIVE. ALL EQUIPMENT LAYOUT, SPECS, PERFORMANCE INSTALLATION AND THEIR FINAL LOCATION ARE TO BE APPROVED BY EXTENET SYSTEMS. THE CONTRACTOR SHALL BE RESPONSIBLE FOR COORDINATING HIS/HER WORK WITH THE WORK AND CLEARANCES REQUIRED BY OTHERS RELATED TO SAID INSTALLATIONS.

extenet SYSTEMS

INTERNAL REVIEW

CONSTRUCTION SIGNATURE	DATE
RF SIGNATURE	DATE
REAL ESTATE SIGNATURE	DATE

NEXIUS
 TRANSFORM YOUR BUSINESS, THROUGH WIRELESS

A&E OFFICE:
 7A LYBERTY WAY
 WESTFORD, MA 01886
 1 (972) 755-1882

THESE DRAWINGS ARE COPYRIGHTED AND ARE THE PROPERTY OF NEXIUS SOLUTIONS, INC. AND PRODUCED SOLELY FOR THE USE OF OUR CLIENT. ANY REPRODUCTION BY USE OF THE INFORMATION CONTAINED WITHIN SAID DRAWINGS IS PROHIBITED WITHOUT WRITTEN CONSENT BY NEXIUS SOLUTIONS, INC.

EXTENET ID:	DRAWN BY:	CHECKED BY:
51177	MH	MDC

SHEET INDEX

SHEET #	SHEET TITLE	ASSOCIATED FILES, DOCUMENTS & APPLICATIONS
T-1	TITLE SHEET	WINDLOAD FILE N/A
A-1	SITE PLANS & SITE PHOTO	JPA APPLICATION N/A
A-2	POLE ELEVATIONS	PGE APPLICATION N/A
RF-1	RF DETAILS	PGE APPLICATION N/A
EQ-1	EQUIPMENT DETAILS	PGE SLA N/A
EQ-2	EQUIPMENT DETAILS	PGE SLA N/A
		MUNICIPAL PERMIT N/A
		ELEC INSPECTION N/A
		EXTENET CONTACT (NOD) 866-892-5327 noc@extenetsystems.com
		CUSTOMER CONTACT N/A
		FIBER CONST PKG. N/A

PROJECT INFORMATION

POLE OWNER		ENGINEER	
COMPANY:	EXTENET JOINT POLE OWNERSHIP	ENGINEER COMPANY:	NEXIUS SOLUTIONS, INC.
CONTACT:	LINDA MCLEAN	ADDRESS:	7A LYBERTY WAY
ADDRESS:	2000 CROW CANYON PLACE SUITE 210 SAN RAMON, CA 94583	PHONE:	(972) 775-1882
EMAIL:	LMCLEAN@EXTENETSYSTEMS.COM		
CONTACTS		PROJECT DATA	
PROJECT MANAGER	EXTENET SYSTEMS, LLC AUDREY DOUGLAS 2000 CROW CANYON PLACE, SUITE 210 SAN RAMON, CA 94583 odouglas@extenetsystems.com	LATITUDE:	37.743312'
APPLICANT COMPANY:	EXTENET SYSTEMS, LLC CRISTOBAL VILLEGAS 2000 CROW CANYON PLACE, SUITE 210 SAN RAMON, CA 94583 cvillegas@extenetsystems.com	LONGITUDE:	-122.162759'
SITE ACQUISITION COMPANY:	NEXIUS SOLUTIONS, INC. 2595 NORTH DALLAS PARKWAY, SUITE 300 FRISCO, TX 75034	POLE #:	52775. 110147975
APPLICANT AGENT COMPANY:	NEXIUS SOLUTIONS, INC. KEI ZUSHI 2595 NORTH DALLAS PARKWAY, SUITE 300 FRISCO, TX 75034 kei.zushi@nexus.com	COUNTY:	ALAMEDA COUNTY
		ZONING JURISDICTION:	CITY OF OAKLAND
		ZONING DISTRICT:	RD-1
		NEAREST APN:	47-5502-20
		OCCUPANCY:	U, UNMANNED
		CONSTRUCTION TYPE:	ATTACHMENTS TO A EXISTING WOOD POLE
		TITLE 24 REQUIREMENTS:	FACILITY IS UNMANNED AND NOT FOR HUMAN HABITATION. THIS PROJECT IS EXEMPT

811

TO GET THE LOCATION OF UNDERGROUND UTILITIES BEFORE YOU START YOUR PROJECT, CALL 811. IT'S THE EASY WAY TO FIND OUT WHERE THE UTILITIES ARE. CALL 811 AT LEAST 48 HOURS BEFORE YOU START YOUR PROJECT.

www.811.org
 1-800-227-2000
 www.811.org
 1-800-227-2000
 www.811.org
 1-800-227-2000

B	07/26/18		PER COMMENTS
A	07/05/18	ZD90	FOR REVIEW
REV	DATE		DESCRIPTION

EXTENET SYSTEMS (CA) LLC
 2000 CROW CANYON PLACE
 SUITE 210
 SAN RAMON, CA 94583

SITE ADDRESS
 ADJACENT TO (IN PROW)
 1900 101ST AVENUE
 OAKLAND, CA 94603

SHEET TITLE
TITLE SHEET

SHEET NUMBER
T-1

Attachment C

11"x17" PLOT, DRAWINGS WILL BE HALF SCALE

SHALL VERIFY ALL PLANS & EXISTING DIMENSIONS & CONDITIONS ON SITE IMMEDIATELY NOTIFY THE ENGINEER IN WRITING OF ANY BEFORE PROCEEDING WITH THE WORK OR BE RESPONSIBLE FOR SAME

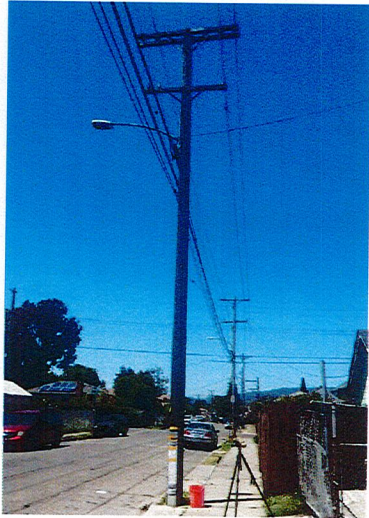

SITE PHOTO
SCALE: N.T.S.

1

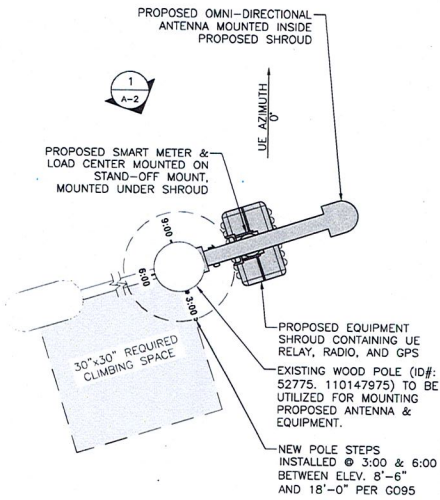

ENLARGED SITE PLAN
SCALE: 1" = 1'-0"

2

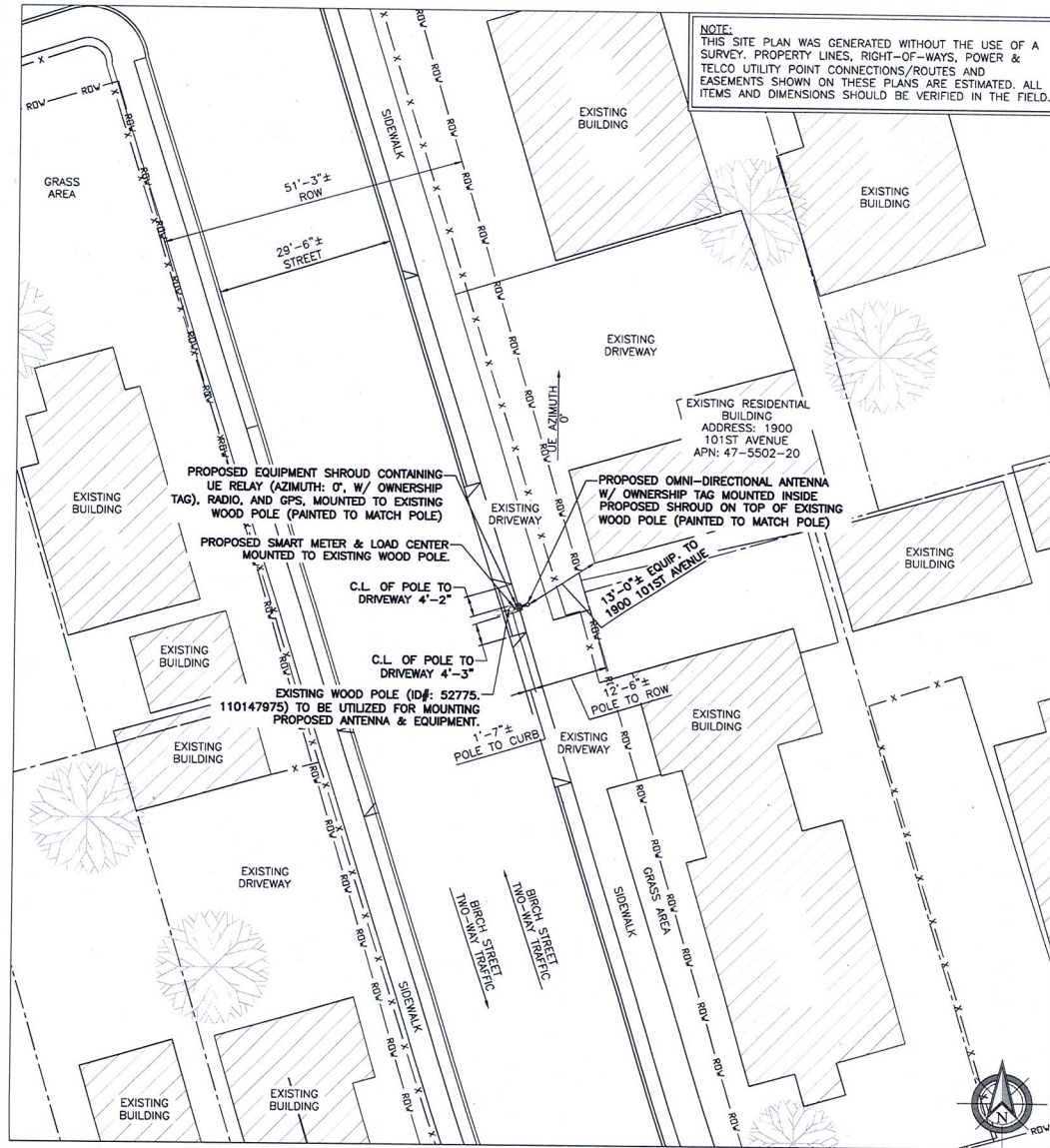

NOTE:
THIS SITE PLAN WAS GENERATED WITHOUT THE USE OF A SURVEY. PROPERTY LINES, RIGHT-OF-WAYS, POWER & TELCO UTILITY POINT CONNECTIONS/ROUTES AND EASEMENTS SHOWN ON THESE PLANS ARE ESTIMATED. ALL ITEMS AND DIMENSIONS SHOULD BE VERIFIED IN THE FIELD.

GRAPHIC SCALE: 1:10 (IN FEET)

SITE PLAN
SCALE: 1:10

3

extenet
SYSTEMS

INTERNAL REVIEW

CONSTRUCTION SIGNATURE	DATE
RF SIGNATURE	DATE
REAL ESTATE SIGNATURE	DATE

NEXIUS
TRANSFORM YOUR BUSINESS... THROUGH WIRELESS

A&E OFFICE:
7A LYBERTY WAY
WESTFORD, MA 01886
1 (877) 755-1882

THESE DRAWINGS ARE COPYRIGHTED AND ARE THE PROPERTY OF NEXIUS SOLUTIONS, INC. AND PRODUCED SOLELY FOR THE USE OF OUR CLIENT. ANY REPRODUCTION OR USE OF THE INFORMATION CONTAINED WITHIN SAID DRAWINGS IS PROHIBITED WITHOUT WRITTEN CONSENT BY NEXIUS SOLUTIONS, INC.

EXTENET ID:	DRAWN BY:	CHECKED BY:
51177	MH	MDC

REV	DATE	DESCRIPTION
B	07/26/18	PER COMMENTS
A	07/05/18	ZD60 FOR REVIEW

FIRM REGISTERED IN CA
IT IS A VIOLATION OF THE LAW FOR ANY PERSON UNLESS THEY ARE ACTING UNDER THE DIRECTION OF A LICENSED PROFESSIONAL ENGINEER, TO ALTER THIS DOCUMENT

EXTENET SYSTEMS (CA) LLC
2000 CROW CANYON PLACE
SUITE 210
SAN RAMON, CA 94583

SITE ADDRESS
ADJACENT TO (IN PROW)
1900 101ST AVENUE
OAKLAND, CA 94603

SHEET TITLE
OVERALL SITE PLAN

SHEET NUMBER
A-1



INTERNAL REVIEW

CONSTRUCTION SIGNATURE _____ DATE _____

RF SIGNATURE _____ DATE _____

REAL ESTATE SIGNATURE _____ DATE _____

NEXIUS
TRANSFORM YOUR BUSINESS...THROUGH WIRELESS

ARE OFFICE
7A LIBERTY WAY
WESTFORD, MA 01886
1 (972) 755-1882

THESE DRAWINGS ARE COPYRIGHTED AND ARE THE PROPERTY OF NEXIUS SOLUTIONS, INC. AND PRODUCED SOLELY FOR THE USE OF OUR CLIENT. ANY REPRODUCTION OR USE OF THE INFORMATION CONTAINED WITHIN SAID DRAWINGS IS PROHIBITED WITHOUT WRITTEN CONSENT BY NEXIUS SOLUTIONS, INC.

EXTENET ID:	DRAWN BY:	CHECKED BY:
51177	MH	MDC

B	07/26/18	PER COMMENTS
A	07/05/18	Z090 FOR REVIEW
REV	DATE	DESCRIPTION

FIRM REGISTERED IN CA

IT IS A VIOLATION OF THE LAW FOR ANY PERSON UNLESS THEY ARE ACTING UNDER THE DIRECTION OF A LICENSED PROFESSIONAL ENGINEER, TO ALTER THIS DOCUMENT

EXTENET SYSTEMS (CA) LLC
2000 CROW CANYON PLACE
SUITE 210
SAN RAMON, CA 94583

SITE ADDRESS
ADJACENT TO (IN PROW)
1900 101ST AVENUE
OAKLAND, CA 94603

SHEET TITLE
POLE ELEVATIONS

SHEET NUMBER
A-2

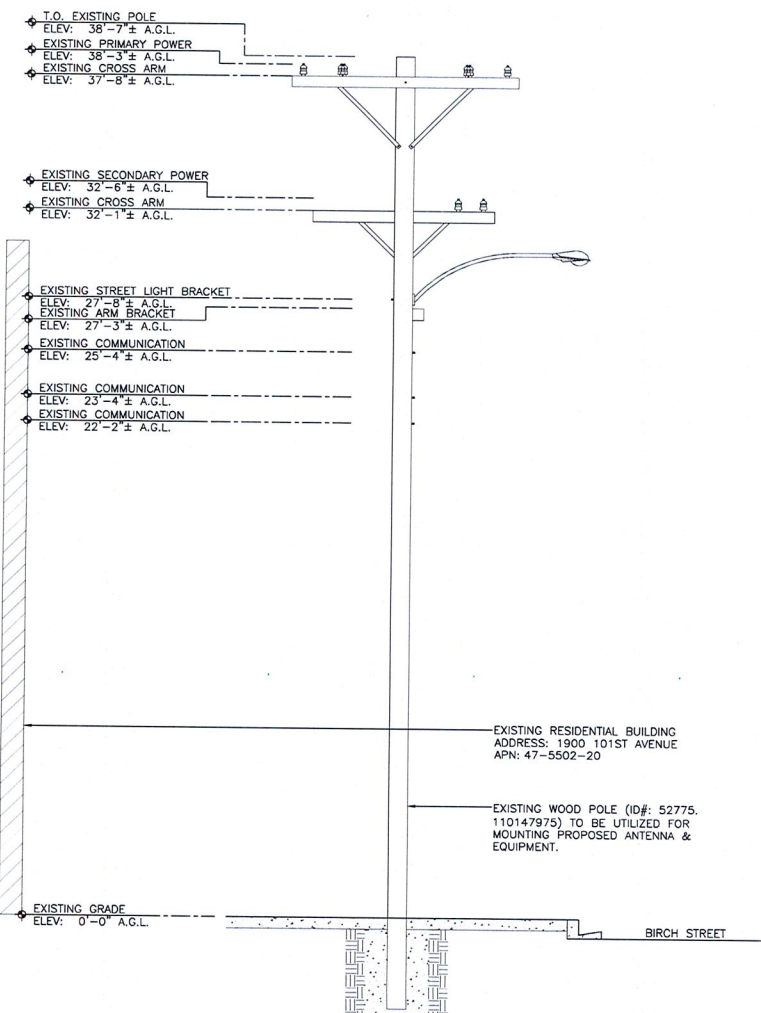

DETAIL A: EXISTING SIDE VIEW LOOKING SOUTHEAST

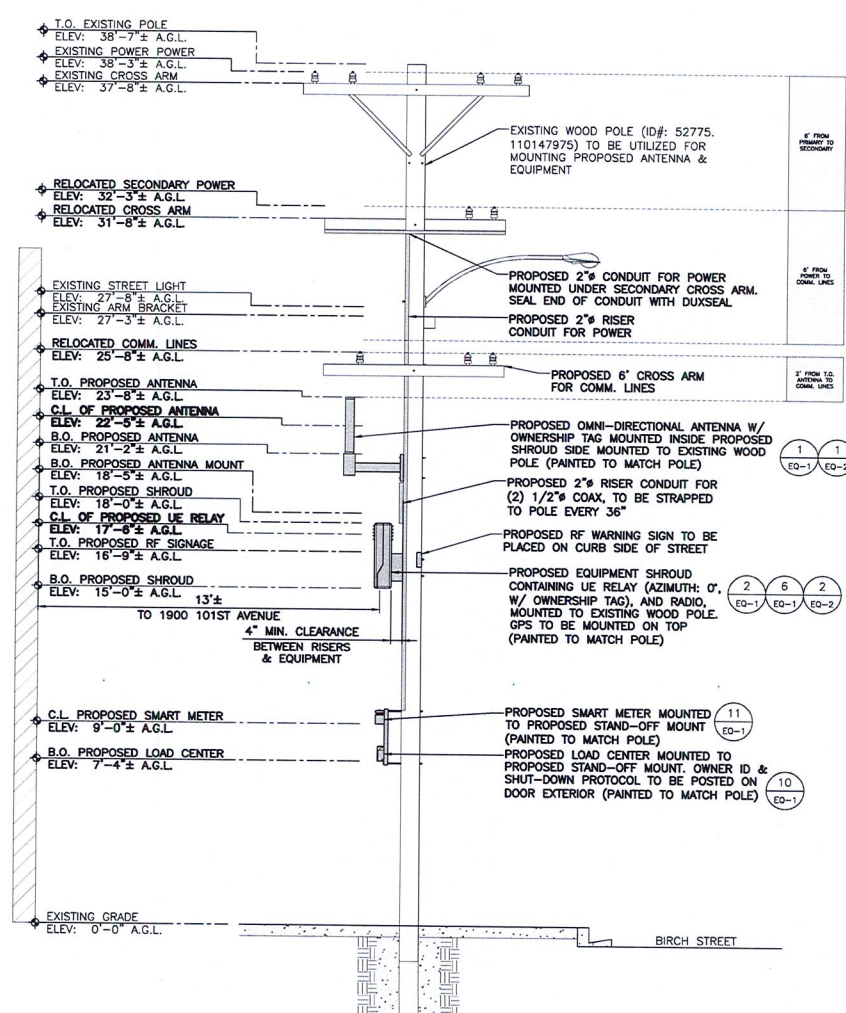

DETAIL B: PROPOSED SIDE VIEW LOOKING SOUTHEAST

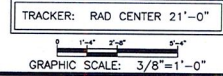

POLE ELEVATIONS

SCALE: 3/8" = 1'-0"

1

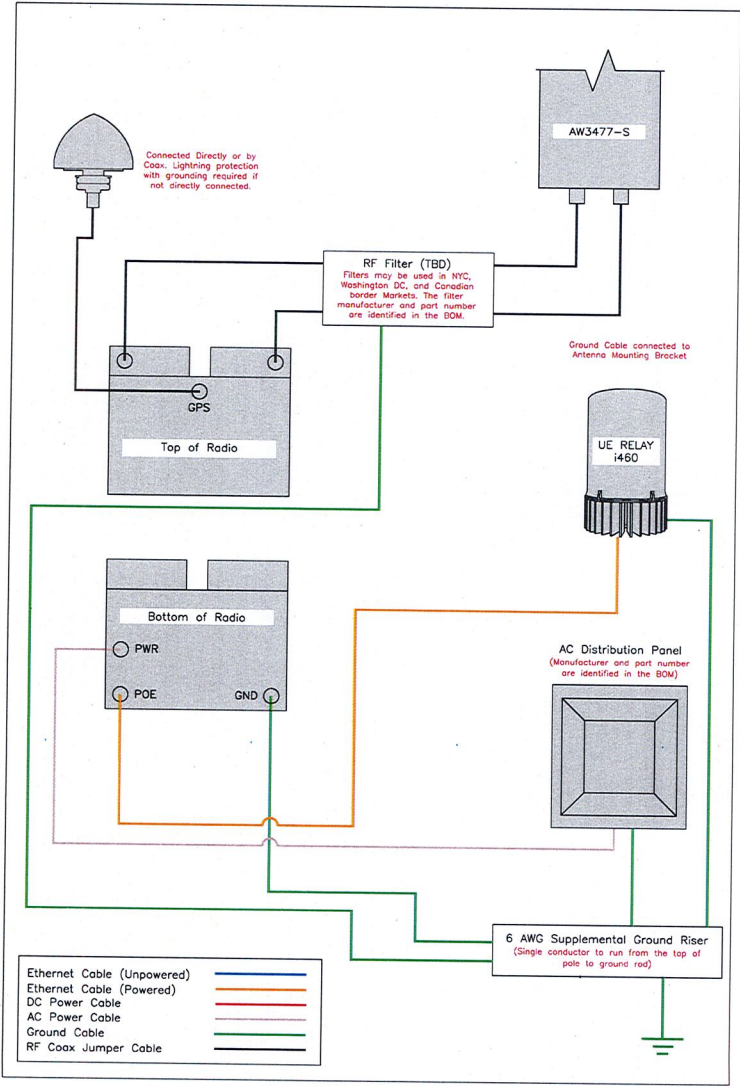

PLUMBING DIAGRAM
SCALE: N.T.S.

1

NOT USED
SCALE: N.T.S.

2

NOT USED
SCALE: N.T.S.

3

extenet
SYSTEMS

INTERNAL REVIEW

CONSTRUCTION SIGNATURE	DATE
RF SIGNATURE	DATE
REAL ESTATE SIGNATURE	DATE

NEXIUS
TRANSFORM YOUR BUSINESS. THROUGH WIRELESS

ARE OFFICE:
7A LYBERTY WAY
WESTFORD, MA 01886
T (972) 755-1882

THESE DRAWINGS ARE COPYRIGHTED AND ARE THE PROPERTY OF NEXIUS SOLUTIONS, INC. AND PRODUCED SOLELY FOR THE USE OF OUR CLIENT. ANY REPRODUCTION OR USE OF THE INFORMATION CONTAINED WITHIN THIS DRAWING IS PROHIBITED WITHOUT WRITTEN CONSENT BY NEXIUS SOLUTIONS, INC.

EXTENET ID:	DRAWN BY:	CHECKED BY:
51177	MH	MDC

REV	DATE	DESCRIPTION
B	07/26/18	PER COMMENTS
A	07/05/18	ZD90 FOR REVIEW

FIRM REGISTERED IN CA
IT IS A VIOLATION OF THE LAW FOR ANY PERSON, UNLESS THEY ARE ACTING UNDER THE DIRECTION OF A LICENSED PROFESSIONAL ENGINEER, TO ALTER THIS DOCUMENT

EXTENET SYSTEMS (CA) LLC
2000 CROW CANYON PLACE
SUITE 210
SAN RAMON, CA 94583

SITE ADDRESS
ADJACENT TO (IN PROW)
1900 101ST AVENUE
OAKLAND, CA 94603

SHEET TITLE
RF DETAILS

SHEET NUMBER
RF-1

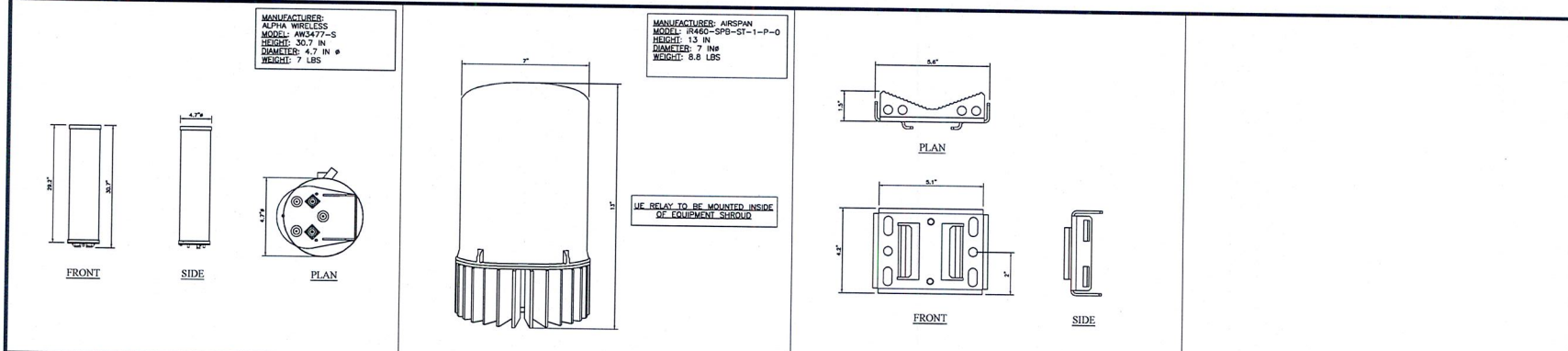

ALPHA WIRELESS AW3477-S SCALE N.T.S. 1 AIRSPAN UE RELAY iR460 SCALE N.T.S. 2 iR460 UE RELAY FLUSH MOUNT SCALE N.T.S. 3 NOT USED SCALE N.T.S. 4

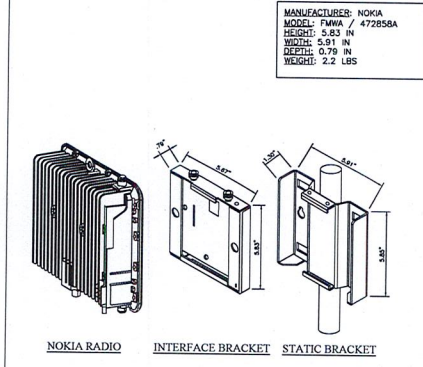
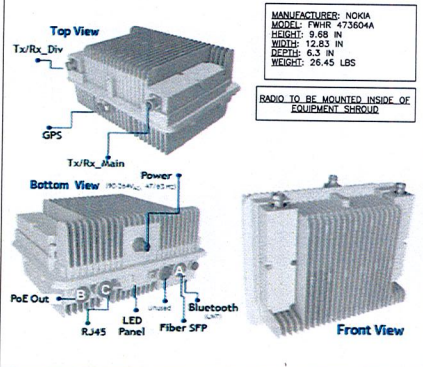
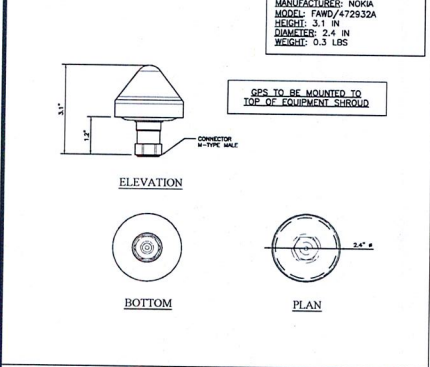

NOKIA GPS FAWD/472932A SCALE N.T.S. 5 NOKIA FWHR 473604A SCALE N.T.S. 6 NOKIA RADIO MOUNT SCALE N.T.S. 7 NOT USED SCALE N.T.S. 8

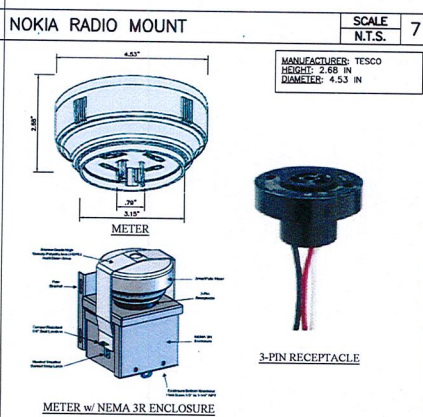
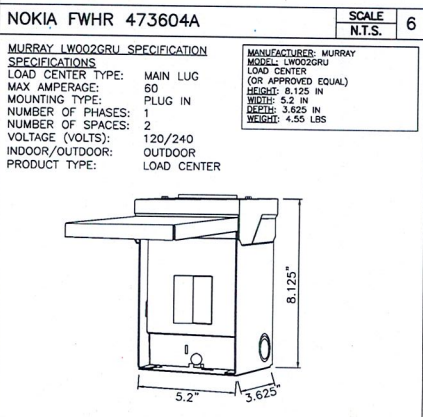
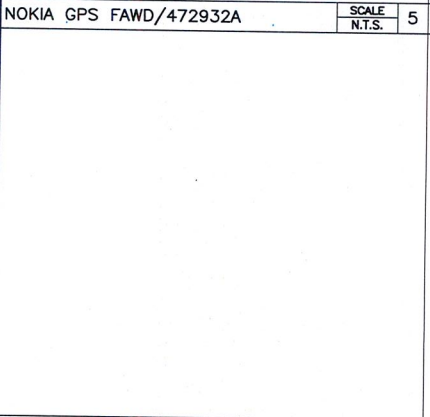

CAUTION

Beyond this point Radio frequency fields at this site may exceed FCC rules for human exposure. For your safety, obey all posted signs and site guidelines for working in radio frequency environments. Workers shall maintain a minimum approach distance of 16 inches.

SITE ID: NW-CA-SANFRNMC-51177
EXTENET SYSTEMS: 1-888-892-6327

NOTICE

Radio frequency fields beyond this point may exceed the FCC general public exposure limit. Obey all posted signs and site guidelines for working in radio frequency environments. Workers shall maintain a minimum approach distance of 16 inches.

SITE ID: NW-CA-SANFRNMC-51177
EXTENET SYSTEMS: 1-888-892-6327

ANTENNA SIGNAGE

- EXTENET TO INSTALL SIGNS PER G095 FULE 94.5 APPENDIX H, EXHIBIT A: AT NODE/ANTENNA POLE.
- SPECIFIC EME PLACARD WILL BE PLACED AFTER EME REPORT.
- ON WOOD POLES; SIGN ON ALUMINUM WITH SS STRAP TO THE POLE.
- ON METAL POLES; ADHESIVE VINYL OR PLACARD STRAPPED WITH SS TIES.
- ON CONCRETE/COMPOSITE; PLACARD STRAPPED WITH SS TIES.
- SIGN PLACEMENT: AFFIX TO THE STRUCTURE 3'-4" BELOW THE COMMERCIAL RF ANTENNA(S) ON CURB SIDE.
- SIZE: APPROX. 8"x5".

NOT USED SCALE N.T.S. 9 MURRAY LOAD CENTER SCALE N.T.S. 10 TESCO SMARTPOLE METER SCALE N.T.S. 11 RF SIGNAGE SCALE N.T.S. 12

extenet
SYSTEMS

INTERNAL REVIEW

CONSTRUCTION SIGNATURE _____ DATE _____

RF SIGNATURE _____ DATE _____

REAL ESTATE SIGNATURE _____ DATE _____

NEXIUS
TRANSFORM YOUR BUSINESS. THROUGH WIRELESS

A&E OFFICE:
7A LIBERTY WAY
WESTFORD, MA 01886
1 (978) 755-1882

THESE DRAWINGS ARE COPYRIGHTED AND ARE THE PROPERTY OF NEXIUS SOLUTIONS, INC. AND PRODUCED SOLELY FOR THE USE OF OUR CLIENT. ANY REPRODUCTION OR USE OF THE INFORMATION CONTAINED WITHIN SAID DRAWINGS IS PROHIBITED WITHOUT WRITTEN CONSENT BY NEXIUS SOLUTIONS, INC.

EXTENET ID	DRAWN BY	CHECKED BY
51177	MH	MDC

REV	DATE	DESCRIPTION
B	07/26/18	PER COMMENTS
A	07/05/18	ZD90 FOR REVIEW

FIRM REGISTERED IN CA
IT IS A VIOLATION OF THE LAW FOR ANY PERSON, UNLESS THEY ARE ACTING UNDER THE DIRECTION OF A LICENSED PROFESSIONAL ENGINEER, TO ALTER THIS DOCUMENT

EXTENET SYSTEMS (CA) LLC
2000 CROW CANYON PLACE
SUITE 210
SAN RAMON, CA 94583

SITE ADDRESS
ADJACENT TO (IN PROW)
1900 101ST AVENUE
OAKLAND, CA 94603

SHEET TITLE
EQUIPMENT DETAILS

SHEET NUMBER
EQ-1

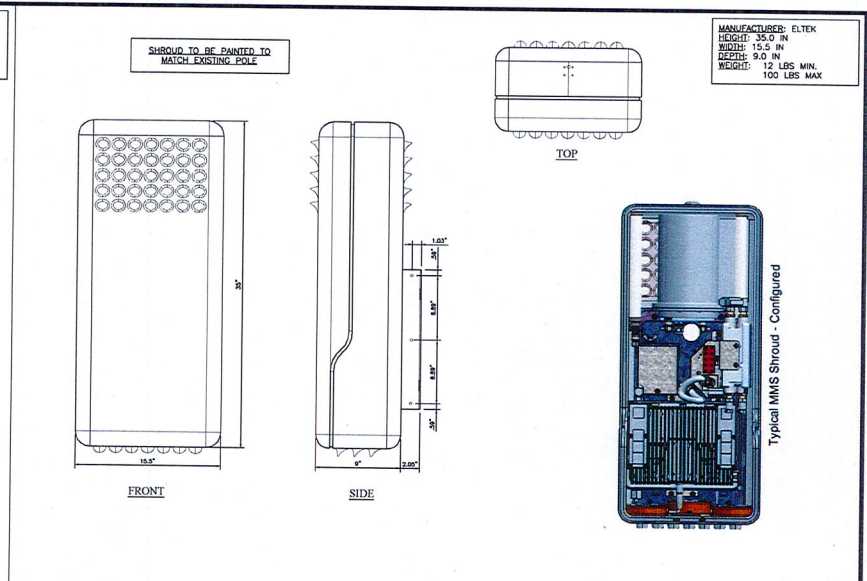
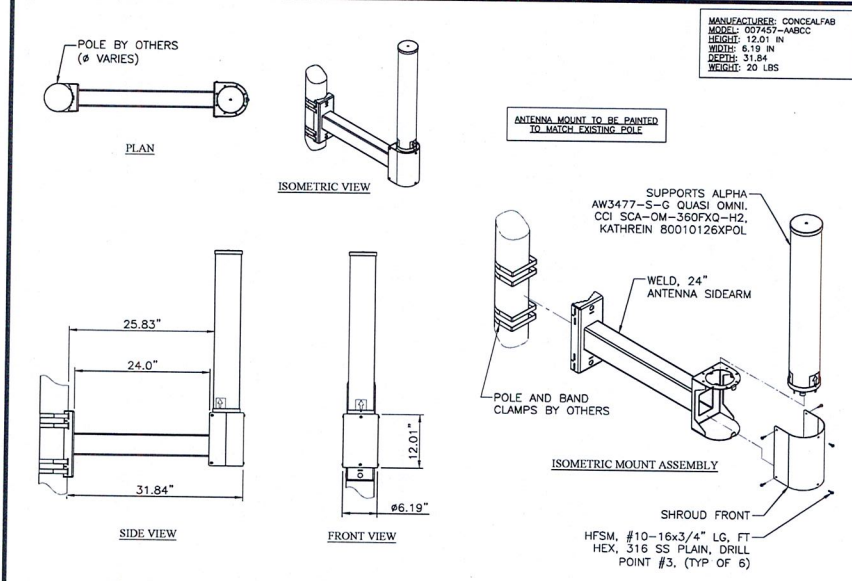

ANTENNA SIDE MOUNT

SCALE 1
N.T.S.

ELTEK MMS EQUIPMENT SHROUD

SCALE 2
N.T.S.

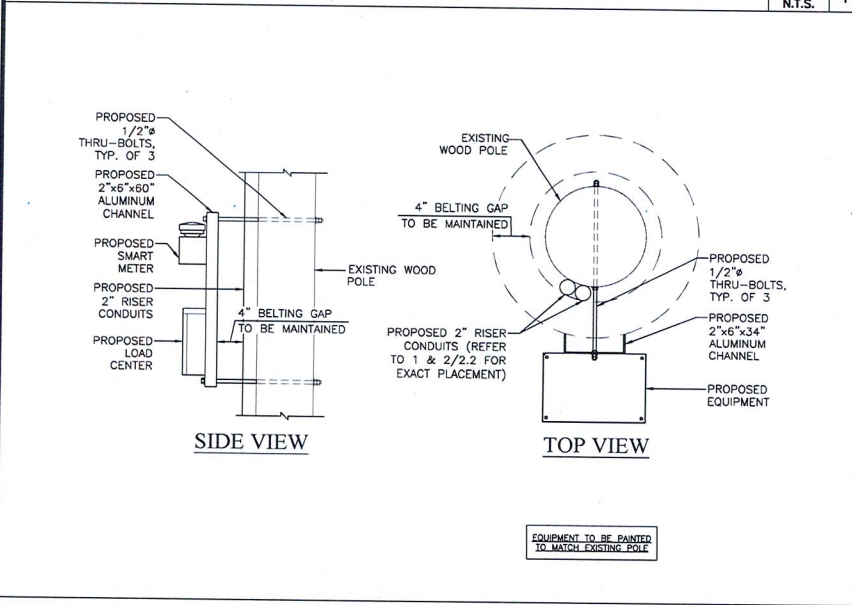

SCALE 3
N.T.S.

EQUIPMENT SHROUD MOUNTING DETAIL

SCALE 4
N.T.S.

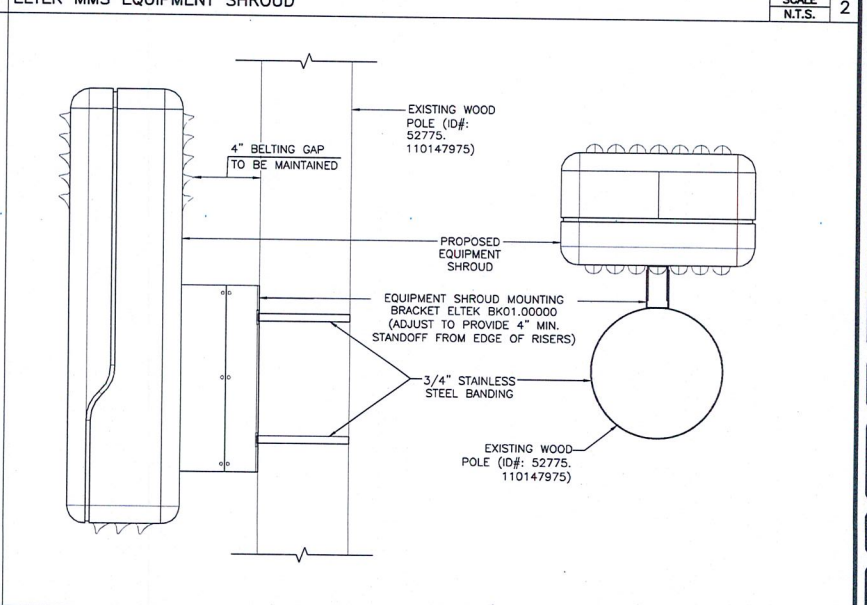

METER & LOAD CENTER MOUNTING DETAIL

extenet
SYSTEMS

INTERNAL REVIEW

CONSTRUCTION SIGNATURE _____ DATE _____

RF SIGNATURE _____ DATE _____

REAL ESTATE SIGNATURE _____ DATE _____

NEXIUS
TRANSFORM YOUR BUSINESS. THROUGH WIRELESS

ARE OFFICE
7A LYBERRY WAY
WESTFORD, MA 01886
1 (972) 755-1882

THESE DRAWINGS ARE COPYRIGHTED AND ARE THE PROPERTY OF NEXIUS SOLUTIONS, INC. AND PROVIDED SOLELY FOR THE USE OF OUR CLIENT. ANY REPRODUCTION OR USE OF THE INFORMATION CONTAINED WITHIN SAID DRAWINGS IS PROHIBITED WITHOUT WRITEN CONSENT BY NEXIUS SOLUTIONS, INC.

EXTENET ID	DRAWN BY	CHECKED BY
51177	MH	MDC

REV	DATE	DESCRIPTION
B	07/26/18	PER COMMENTS
A	07/05/18	ZDRD FOR REVIEW

FIRM REGISTERED IN CA
IF IT IS A VIOLATION OF THE LAW FOR ANY PERSON UNLESS THEY ARE ACTING UNDER THE DIRECTION OF A LICENSED PROFESSIONAL ENGINEER TO ALTER THIS DOCUMENT

EXTENET SYSTEMS (CA) LLC
2000 CROW CANYON PLACE
SUITE 210
SAN RAMON, CA 94583

SITE ADDRESS
ADJACENT TO (IN PROW)
1900 101ST AVENUE
OAKLAND, CA 94603

SHEET TITLE
EQUIPMENT DETAILS

SHEET NUMBER
EQ-2

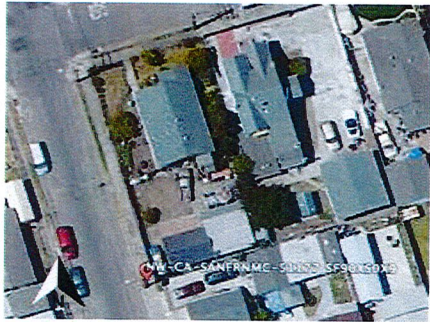

LOCATION

Address: 1900 101ST AVENUE (BIRCH STREET FRONTAGE) OAKLAND, CA 94603

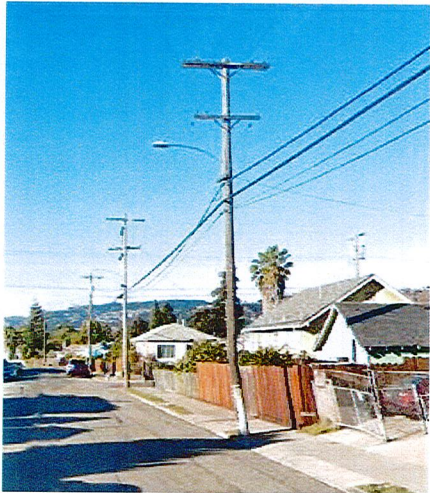

EXISTING



PROPOSED - NORTH

extenet
mConnectivity
SYSTEMS
Everywhere
2000 Crow Canyon Place, Suite 210 San Ramon, CA 94583

Photo Simulation
Site: NW-CA-SANFRNMC-51177
SF90XS0X9-L

Disclaimer: These photographic simulations have been provided to aid in visualizing how the proposed wireless telecommunications facility shown herein would appear if constructed. While these renderings are not an exact science, they have been prepared diligently to accurately reflect dimensions, scale, depth, coloring, texture, and other important elements in the proposed design insofar as the digital medium allows. Taken together with the engineering drawings and other materials submitted with the application, they are fair and reasonable visual depictions of how the proposed site would appear.

ATA
DEVELOPMENT, INC.

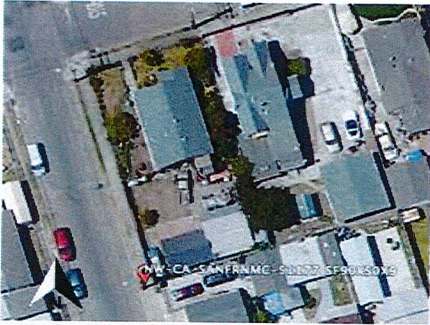

LOCATION

Address: 1900 101ST AVENUE (BIRCH STREET FRONTAGE) OAKLAND, CA 94603

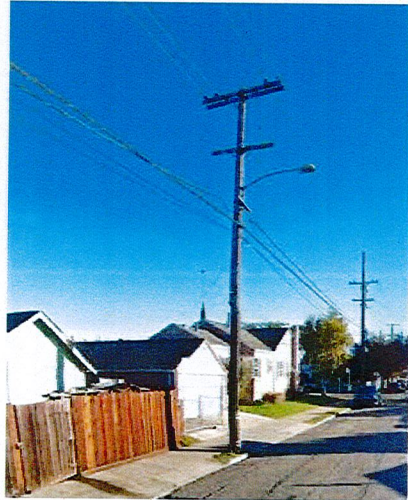

EXISTING



PROPOSED -

extenet[®] mConnectivity
SYSTEMS Everywhere
2000 Crow Canyon Place, Suite 210 San Ramon, CA 94583

Photo Simulation
Site: NW-CA-SANFRNMC-51177
SF90XS0X9-L

Disclaimer: These photographic simulations have been provided to aid in visualizing how the proposed wireless telecommunications facility shown herein would appear if constructed. While these renderings are not an exact science, they have been prepared diligently to accurately reflect dimensions, scale, depth, coloring, texture, and other important elements in the proposed design insofar as the digital medium allows. Taken together with the engineering drawings and other materials submitted with the application, they are fair and reasonable visual depictions of how the proposed site would appear.

ATA
DEVELOPMENT, INC.

Alternative Site Analysis

Extenet Site Name: SF90XS0X9

Site Address: Near 1900 101st Ave, Oakland, CA 94609

Preferred Candidate:



Alternate #1: Coordinates: 37°44'34.91"N, 122° 9'45.66"W

Reason not suitable for wireless site: Pole does not meet GO95 standards.



Alternate #2: Coordinates: 37°44'35.99"N, 122° 9'45.11"W

Reason not suitable for wireless site: Pole does not meet GO95 standards.



Radio Frequency – Electromagnetic Energy (RF-EME) Compliance Report

Site No. NW-CA-SANFRNMC- 51177

SF90XS0X9

1900 101st Avenue (Birch St Frontage)

Oakland, California 94603

Alameda County

37.743312; -122.162759 NAD83

Light Pole

EBI Project No. 6218006663

October 16, 2018

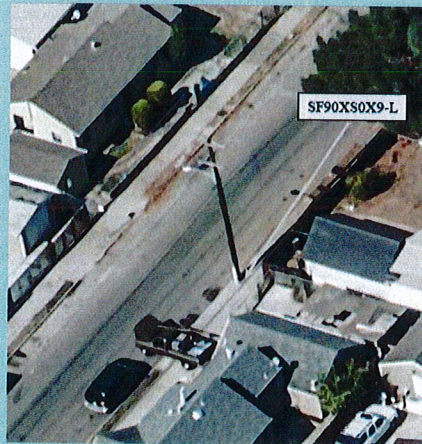

Prepared for:

ExteNet

3030 Warrenville Road, Suite 340

Lisle, IL 60532

Prepared by:



EXECUTIVE SUMMARY

Purpose of Report

EnviroBusiness Inc. (dba EBI Consulting) has been contracted by ExteNet to conduct radio frequency electromagnetic (RF-EME) modeling for ExteNet Site NW-CA-SANFRNMC- 51177 (Sprint Site SF90XS0X9) located at 1900 101st Avenue (Birch St Frontage) in Oakland, California to determine RF-EME exposure levels from proposed wireless communications equipment at this site. As described in greater detail in Appendix A of this report, the Federal Communications Commission (FCC) has developed Maximum Permissible Exposure (MPE) Limits for general public exposures and occupational exposures. This report summarizes the results of RF-EME modeling in relation to relevant FCC RF-EME compliance standards for limiting human exposure to RF-EME fields.

This report contains a detailed summary of the RF EME analysis for the site.

This document addresses the compliance of proposed transmitting facilities independently at the site.

Modeling results included in this report are based on drawings dated July 26, 2018 as provided to EBI Consulting. Subsequent changes to the drawings or site design may yield changes in the MPE levels or FCC Compliance recommendations.

Maximum Permissible Exposure (MPE) Summary				
Location	% of FCC General Public/Uncontrolled Exposure Limit	% of FCC Occupational/Controlled Exposure Limit	Power Density (mW/cm²)	Occupational Approach Distance (ft)
Proposed Equipment				
Antenna Face Level	121.20	24.24	1.2120	<1' 0"
UE Relay Level	112.00	22.40	1.12000	<1' 0"
Ground	4.30	0.86	0.0430	<1' 0"
Adjacent Building	2.45	0.49	0.0245	<1' 0"

For a person anywhere at ground level, the maximum RF exposure level due to the proposed Sprint operation is calculated to be 0.0430 mW/cm², which is 4.30% of the applicable general public exposure limit. The maximum calculated level at any nearby adjacent structure is 2.45% of the general public exposure limit. The adjacent building refers to the single story building to the northeast of the pole.

These results are calculated based on max power assumptions for this site. The mounted antenna will contribute the majority to these emissions. Additional equipment to be installed is operating at very low power and contributions to the overall site emission is marginal. Workers accessing any equipment on this pole should follow all safety procedures outlined by the carrier and pole owners.

Statement of Compliance

Based on worst-case predictive modeling, there are no modeled exposures on any accessible ground-level or adjacent building walking/working surface related to proposed equipment in the area that exceed the FCC's occupational and/or general public exposure limits at this site. As such, the proposed project is in compliance with FCC rules and regulations.

Signage recommendations are presented in Section 9.0 to bring the site into compliance with the FCC Rules and Regulations.

1.0 LOCATION OF ALL PROPOSED ANTENNAS AND FACILITIES AND PROPOSED RF LEVELS

ExteNet proposes the installation of one (1) Sprint wireless telecommunication antenna and one (1) UE Relay on a light pole in Oakland, California. The proposed site will have a total of one (1) antenna and one (1) UE Relay at the site.

There are no collocated carriers on the light pole.

2.0 LOCATION OR ALL APPROVED (BUT NOT INSTALLED) ANTENNAS AND FACILITIES AND EXPECTED RF LEVELS FROM THE APPROVED FACILITIES

There are no antennas or facilities that are approved and not installed based on information provided to EBI and ExteNet at the time of this report.

3.0 NUMBER AND TYPES OF WIRELESS TELECOMMUNICATION SITES (WTS) WITHIN 100 FEET OF THE PROPOSED SITE

Based on aerial photography review, there are no other Wireless Telecommunication Service (WTS) sites observed within 100 feet of the proposed site.

4.0 LOCATION AND NUMBER OF THE ANTENNAS AND BACK-UP FACILITIES PER STRUCTURE AND NUMBER AND LOCATION OF OTHER TELECOMMUNICATION FACILITIES ON THE PROPERTY

ExteNet proposes the installation of one (1) Sprint wireless telecommunication antenna and one (1) UE Relay on a light pole in Oakland, California. The proposed site will have a total of one (1) antenna and one (1) UE Relay at the site.

There is one sector proposed at this site with one antenna and one UE Relay in that sector. The antenna is transmitting omnidirectionally in the 2500 Mhz Frequency range. The bottom of the antenna will be 21.2 feet above the ground level. The UE Relay will be oriented 0° from true north and transmitting in the 2500 MHz frequency range. The bottom of the UE Relay will be 17.0 feet above ground level.

There are no collocated carriers on the light pole.

5.0 POWER RATING FOR ALL PROPOSED BACKUP EQUIPMENT SUBJECT TO THE APPLICATION

The operating power of each frequency, for modeling purposes, was assumed to be the following:

Sprint Operating Powers Per Sector		
Frequency (MHz)	Power (Watts)	# of Transmitters
Sprint Antenna 2500	20	2
Sprint UE Relay 2500	0.2	2

Additional transmitter information used in the modeling of Sprint antenna(s) is summarized in the RoofView® export file presented in Appendix C.

6.0 TOTAL NUMBER OF WATTS PER INSTALLATION AND THE TOTAL NUMBER OF WATTS FOR ALL INSTALLATIONS ON THE STRUCTURE

The Effective Radiated Power (ERP) for each carrier and frequency is summarized below:

Effective Radiated Power (ERP) per Frequency	
Frequency (MHz)	ERP (Watts)
Sprint Antenna 2500	173
Sprint UE Relay 2500	4

7.0 PREFERRED METHOD OF ATTACHMENT OF PROPOSED ANTENNA INCLUDING DIRECTIONALITY OF ANTENNAS AND HEIGHT OF ANTENNAS ABOVE NEAREST WALKING SURFACE

Based on the information provided to EBI, the proposed antenna(s) will be mounted to an existing light pole and operating in the directions, frequencies, and heights mentioned in section 4.0 above.

8.0 ESTIMATED AMBIENT RADIO FREQUENCY FIELDS FOR THE PROPOSED SITE

Based on worst-case predictive modeling, there are no modeled exposures on any accessible ground-level or adjacent building walking/working surface related to proposed equipment in the area that exceed the FCC's occupational and/or general public exposure limits at this site. As such, the proposed project is in compliance with FCC rules and regulations.

Maximum Permissible Exposure (MPE) Summary				
Location	% of FCC General Public/Uncontrolled Exposure Limit	% of FCC Occupational/Controlled Exposure Limit	Power Density (mW/cm ²)	Occupational Approach Distance (ft)
Proposed Equipment				
Antenna Face Level	121.20	24.24	1.2120	<1' 0"
UE Relay Level	112.00	22.40	1.12000	<1' 0"
Ground	4.30	0.86	0.0430	<1' 0"
Adjacent Building	2.45	0.49	0.0245	<1' 0"

It is recommended that the general public maintain a 3ft setback from the antenna and UE Relay. The inputs used in the modeling are summarized in the RoofView® export file presented in Appendix C.

9.0 SIGNAGE AT THE FACILITY IDENTIFYING ALL WTS EQUIPMENT AND SAFETY PRECAUTIONS FOR PEOPLE NEARING THE EQUIPMENT AS MAY BE REQUIRED BY THE APPLICABLE FCC ADOPTED STANDARDS

Signs are the primary means for control of access to areas where RF exposure levels may potentially exceed the MPE. However, it is not recommended that signage be placed in highly public areas where there are no exposures above the FCC general public limits. Signage at this site should be installed following carrier and local jurisdiction requirements. Additionally, any elevated workers should be alerted to any potential exposures at the antenna face. There are no exposures above the FCC limits at ground level and therefore barriers are not recommended.

Workers that are elevated above the ground may be exposed to power densities greater than the applicable FCC limits. Workers should be informed via signage about the presence of antennas and their associated fields and practice RF Safety Procedures.

Access to this site is accomplished by approaching the light pole at ground level. Access to the antenna is gained via a lift or climbing with fall protection and therefore the antenna is not considered to be accessible to the general public.

10.0 STATEMENT ON PRODUCTION OF THIS REPORT AND QUALIFICATIONS

Please see the certifications attached in Appendix B below.

11.0 LIMITATIONS

This report was prepared for the use of ExteNet. It was performed in accordance with generally accepted practices of other consultants undertaking similar studies at the same time and in the same locale under like circumstances. The conclusions provided by EBI are based solely on the information provided by the client. The observations in this report are valid on the date of the investigation. Any additional information that becomes available concerning the site should be provided to EBI so that our conclusions may be revised and modified, if necessary. This report has been prepared in accordance with Standard Conditions for Engagement and authorized proposal, both of which are integral parts of this report. No other warranty, expressed or implied, is made.

12.0 SUMMARY AND CONCLUSIONS

EBI has prepared this Radiofrequency Emissions Compliance Report for the proposed Sprint telecommunications equipment at the site located at 1900 101st Avenue (Birch St Frontage) in Oakland, California.

EBI has conducted theoretical modeling to estimate the worst-case power density from proposed the Sprint antenna(s) to document potential MPE levels at this location and ensure that site control measures are adequate to meet FCC and OSHA requirements. As presented in the preceding sections, based on worst-case predictive modeling, there are no modeled exposures on any accessible ground-level or adjacent building walking/working surface related to proposed equipment in the area that exceed the FCC's occupational and/or general public exposure limits at this site. As such, the proposed project is in compliance with FCC rules and regulations.

Signage is recommended at the site as presented in Section 9.0. Posting of the signage brings the site into compliance with FCC rules and regulations.

Appendix A
Federal Communications
Commission (FCC) Requirements

The FCC has established Maximum Permissible Exposure (MPE) limits for human exposure to Radiofrequency Electromagnetic (RF-EME) energy fields, based on exposure limits recommended by the National Council on Radiation Protection and Measurements (NCRP) and, over a wide range of frequencies, the exposure limits developed by the Institute of Electrical and Electronics Engineers, Inc. (IEEE) and adopted by the American National Standards Institute (ANSI) to replace the 1982 ANSI guidelines. Limits for localized absorption are based on recommendations of both ANSI/IEEE and NCRP.

The FCC guidelines incorporate two separate tiers of exposure limits that are based upon occupational/controlled exposure limits (for workers) and general public/uncontrolled exposure limits for members of the general public.

Occupational/controlled exposure limits apply to situations in which persons are exposed as a consequence of their employment and in which those persons who are exposed have been made fully aware of the potential for exposure and can exercise control over their exposure. Occupational/controlled exposure limits also apply where exposure is of a transient nature as a result of incidental passage through a location where exposure levels may be above general public/uncontrolled limits (see below), as long as the exposed person has been made fully aware of the potential for exposure and can exercise control over his or her exposure by leaving the area or by some other appropriate means.

General public/uncontrolled exposure limits apply to situations in which the general public may be exposed or in which persons who are exposed as a consequence of their employment may not be made fully aware of the potential for exposure or cannot exercise control over their exposure. Therefore, members of the general public would always be considered under this category when exposure is not employment-related, for example, in the case of a telecommunications tower that exposes persons in a nearby residential area.

Table I and Figure I (below), which are included within the FCC's OET Bulletin 65, summarize the MPE limits for RF emissions. These limits are designed to provide a substantial margin of safety. They vary by frequency to take into account the different types of equipment that may be in operation at a particular facility and are "time-averaged" limits to reflect different durations resulting from controlled and uncontrolled exposures.

The FCC's MPEs are measured in terms of power (mW) over a unit surface area (cm²). Known as the power density, the FCC has established an occupational MPE of 5 milliwatts per square centimeter (mW/cm²) and an uncontrolled MPE of 1 mW/cm² for equipment operating in the 1900 MHz and 2500 MHz frequency ranges. These limits are considered protective of these populations.

Table I: Limits for Maximum Permissible Exposure (MPE)				
(A) Limits for Occupational/Controlled Exposure				
Frequency Range (MHz)	Electric Field Strength (E) (V/m)	Magnetic Field Strength (H) (A/m)	Power Density (S) (mW/cm ²)	Averaging Time [E] ² , [H] ² , or S (minutes)
0.3-3.0	614	1.63	(100)*	6
3.0-30	1842/f	4.89/f	(900/f ²)*	6
30-300	61.4	0.163	1.0	6
300-1,500	--	--	f/300	6
1,500-100,000	--	--	5	6
(B) Limits for General Public/Uncontrolled Exposure				
Frequency Range (MHz)	Electric Field Strength (E) (V/m)	Magnetic Field Strength (H) (A/m)	Power Density (S) (mW/cm ²)	Averaging Time [E] ² , [H] ² , or S (minutes)
0.3-1.34	614	1.63	(100)*	30
1.34-30	824/f	2.19/f	(180/f ²)*	30
30-300	27.5	0.073	0.2	30
300-1,500	--	--	f/1,500	30
1,500-100,000	--	--	1.0	30

f = Frequency in (MHz)

* Plane-wave equivalent power density

Figure 1. FCC Limits for Maximum Permissible Exposure (MPE)
 Plane-wave Equivalent Power Density

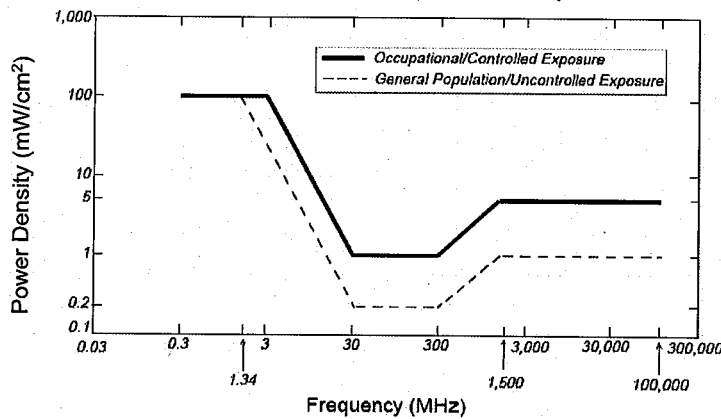

Based on the above, the most restrictive thresholds for exposures of unlimited duration to RF energy for several personal wireless services are summarized below:

Personal Wireless Service	Approximate Frequency	Occupational MPE	Public MPE
Personal Communication (PCS)	1,950 MHz	5.00 mW/cm ²	1.00 mW/cm ²
Cellular Telephone	870 MHz	2.90 mW/cm ²	0.58 mW/cm ²
Specialized Mobile Radio	855 MHz	2.85 mW/cm ²	0.57 mW/cm ²
Most Restrictive Freq, Range	30-300 MHz	1.00 mW/cm ²	0.20 mW/cm ²

MPE limits are designed to provide a substantial margin of safety. These limits apply for continuous exposures and are intended to provide a prudent margin of safety for all persons, regardless of age, gender, size, or health.

Personal Communication System (PCS) facilities used by Sprint in this area operate within a frequency range of 800-1900 MHz. Facilities typically consist of: 1) electronic transceivers (the radios or cabinets) connected to wired telephone lines; and 2) antennas that send the wireless signals created by the transceivers to be received by individual subscriber units (PCS telephones). Transceivers are typically connected to antennas by coaxial cables.

Advanced Wireless Services (AWS) facilities used by the carrier in this area operate within a frequency range of 2496 - 2690 MHz. Facilities typically consist of: 1) electronic transceivers (the radios or cabinets); and 2) antennas that send the wireless signals created by the transceivers to be received by individual subscriber units. Transceivers are typically connected to antennas by coaxial cables.

Because of the short wavelength of PCS/AWS services, the antennas require line-of-site paths for good propagation, and are typically installed above ground level. Antennas are constructed to concentrate energy towards the horizon, with as little energy as possible scattered towards the ground or the sky. This design, combined with the low power of PCS facilities, generally results in no possibility for exposure to approach Maximum Permissible Exposure (MPE) levels, with the exception of areas directly in front of the antennas.

FCC Compliance Requirement

A site is considered out of compliance with FCC regulations if there are areas that exceed the FCC exposure limits and there are no RF hazard mitigation measures in place. Any carrier which has an installation that contributes more than 5% of the applicable MPE must participate in mitigating these RF hazards.

Appendix B

Certifications

Reviewed and Approved by:

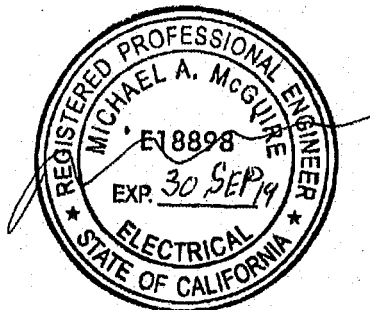

sealed 17oct2018

Michael McGuire
Electrical Engineer

Note that EBI's scope of work is limited to an evaluation of the Radio Frequency – Electromagnetic Energy (RF-EME) field generated by the antennas and broadcast equipment noted in this report. The engineering and design of the structure, as well as the impact of the antennas and broadcast equipment on the structural integrity of the structure, are specifically excluded from EBI's scope of work.

Preparer Certification

I, David Keirstead, state that:

- I am an employee of EnviroBusiness Inc. (d/b/a EBI Consulting), which provides RF-EME safety and compliance services to the wireless communications industry.
- I have successfully completed RF-EME safety training, and I am aware of the potential hazards from RF-EME and would be classified "occupational" under the FCC regulations.
- I am familiar with the FCC rules and regulations as well as OSHA regulations both in general and as they apply to RF-EME exposure.
- I have reviewed the data provided by the client and incorporated it into this Site Compliance Report such that the information contained in this report is true and accurate to the best of my knowledge.

David Keirstead

Appendix C

Roofview® Export File / Antenna Inventory

Map, Settings, Antenna, and Symbol Data Table .. Exported from workbook -> RoofView 4.15.xls
 Done on 8/14/2018 at 5:12:26 PM.
 Use this format to prepare other data sets for the RoofView workbook file.
 You may use as many rows in this TOP header as you wish.
 The critical point are the cells in COLUMN ONE that read 'Start...'. (eg. StartMapDefinition)
 If used, these (4) headers are required to be spelled exactly, as one word (eg. StartMapDefinition)
 The very next row will be considered the start of that data block.
 The first row of the data block can be a header (as shown below), but this is optional.
 When building a text file for import, Add the Map info first, then the Antenna data, followed by the symbol data.
 All rows above the first marker line 'Start...' will be ignored, no matter how many there are.
 This area is for you use for documentation.
 End of help comments.

You can place as much text here as you wish as long as you don't place it below
 the Start Map Definition row below the blue line.
 You may insert more rows using the Insert menu.
 Should you need additional lines to document your project, simply insert additional rows
 by highlighting the row number adjacent to the blue line below and then clicking on the Insert menu
 and selecting rows.

StartMapDefinition

Roof Max Roof Max Map Max ' Map Max : Y Offset X Offset Number o envelope
 100 100 100 100 0 0 1 \$U\$41:\$FX \$U\$41:\$FX\$210

StartSettingsData

Standard Method Uptime Scale Fact Low Thr Low Color Mid Thr Mid Color HI Thr HI Color Over Colo Ap Ht Mult Ap Ht Method
 4 2 3 1 100 1 500 4 5000 2 3 1.5 1

StartAntennaData

It is advisable to provide an ID (ant 1) for all antennas

ID	Name	Freq (MHz)	Trans Power	Trans Count	Coax Len	Coax Type	Other Loss	Input Power	Calc Power	Mfg	Model	(ft) X	(ft) Y	(ft) Z	Type	(ft) Aper	dBd Gain	BWdth Pt Dir	Uptime Profile	ON flag
SPT1	Sprint	2500	20	2	0	0	0	0	0	40 Alpha	AW3477-S	30	30	21.201		2.43	6.35 OMNI		ON*	
UE1	UE Relay	2500	0.2	2	0	0	0	0	0	0.4 AirSpan	iRelay 460	30	30	16.96		1.08	9.85 35;0		ON*	

StartSymbolData

Sym	Map Mark	Roof X	Roof Y	Map Label	Description (notes for this table only)
Sym			5	35 AC Unit	Sample symbols
Sym			14	5 Roof Access	
Sym			45	5 AC Unit	
Sym			45	20 Ladder	

3A

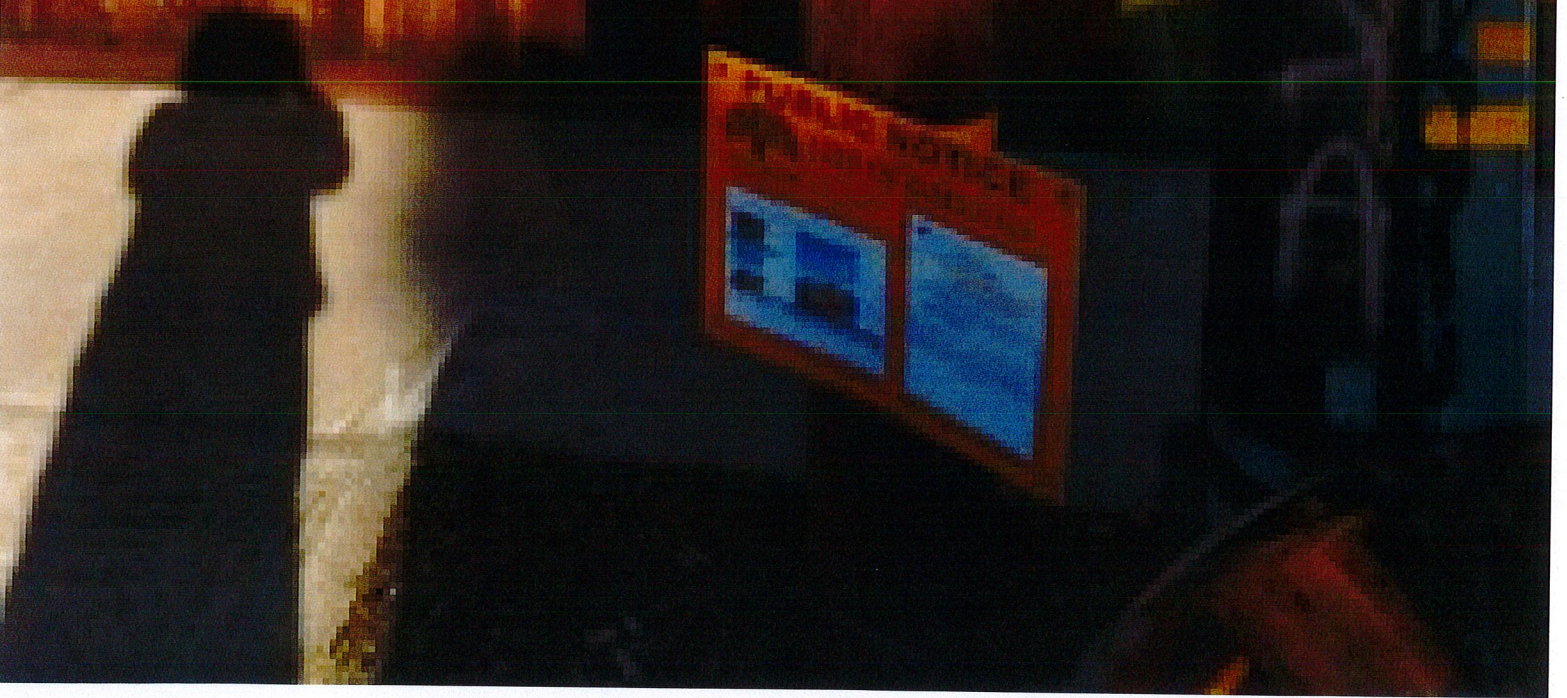
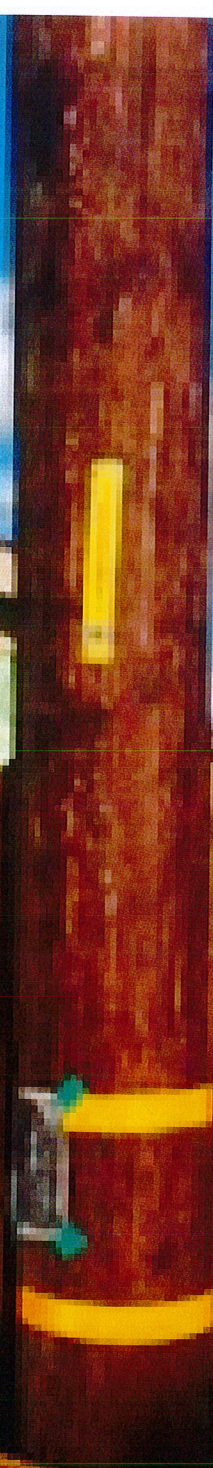
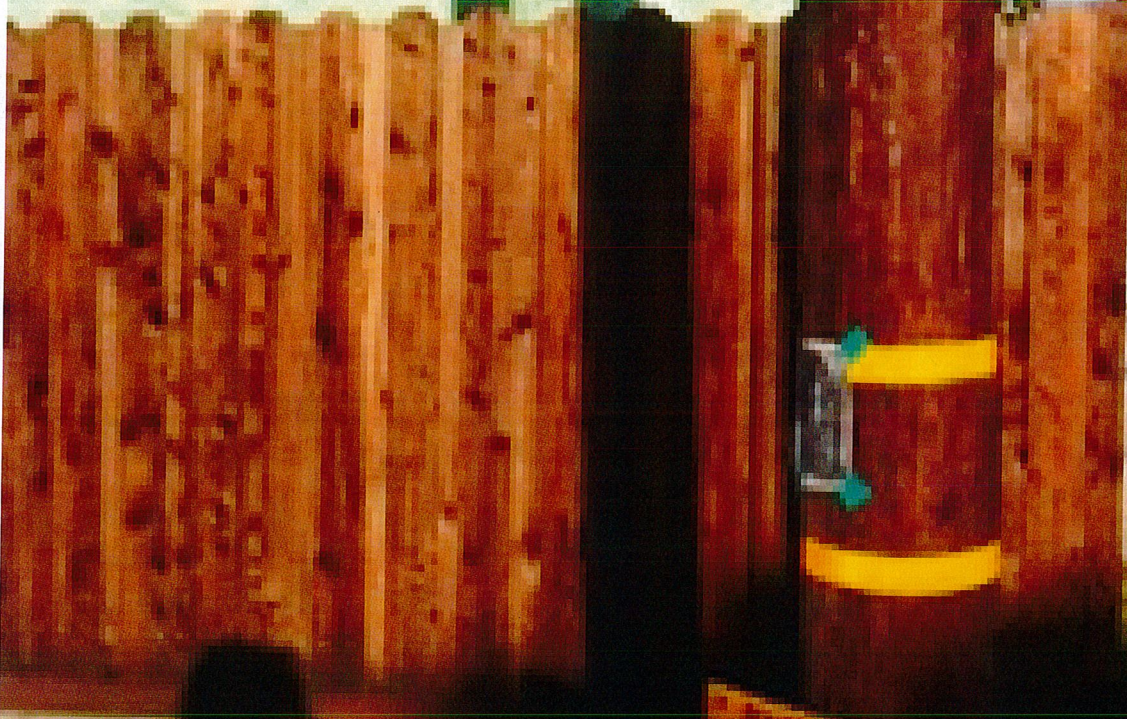



NW-CA-SANFRNMC-51166
SF90XS1N7-M
1607 CHURCH ST
OAKLAND, CA 94621

SITE TYPE: WOOD POLE IN PROW
POLE REPLACEMENT: NO
POWER: PGE
CARRIER: SPRINT

LOCAL MAP

NOT TO SCALE

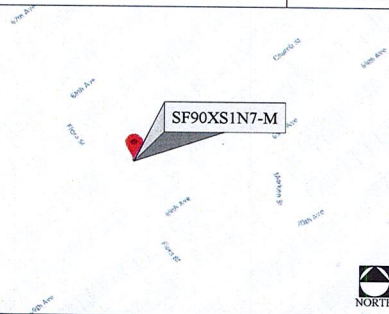

VICINITY MAP

NOT TO SCALE

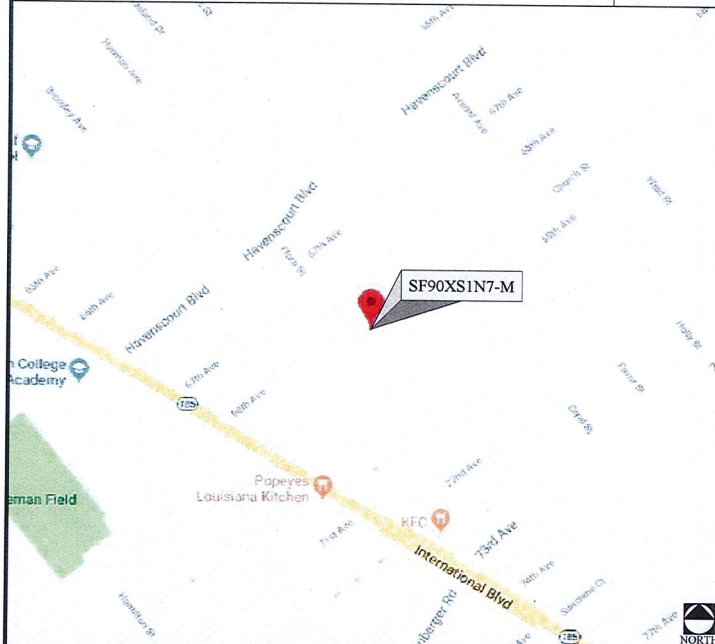

CODE COMPLIANCE

ALL WORK AND MATERIALS SHALL BE PERFORMED AND INSTALLED IN ACCORDANCE WITH THE CURRENT EDITIONS OF THE FOLLOWING CODES AS ADOPTED BY THE LOCAL GOVERNING AUTHORITIES (AS APPLICABLE). NOTHING IN THESE PLANS IS TO BE CONSTRUCTED TO PERMIT WORK NOT CONFORMING TO THESE CODES.

- 2015 INTERNATIONAL BUILDING CODE
- CALIFORNIA BUILDING STANDARDS CODE-2016
- CALIFORNIA GENERAL ORDER 95
- CALIFORNIA MECHANICAL CODE 2016
- CALIFORNIA PLUMBING CODE 2016
- CALIFORNIA ELECTRICAL CODE 2016
- CITY AND/OR COUNTY ORDINANCES
- 2012 INTERNATIONAL FIRE CODE

PROJECT DESCRIPTION

THESE DRAWINGS DEPICT THE INSTALLATION OF A WIRELESS TELECOMMUNICATIONS FACILITY IN THE PUBLIC RIGHT OF WAY. HARDWARE AND ANCILLARY EQUIPMENT TO BE INSTALLED AS DESCRIBED HEREIN.

GENERAL PROJECT NOTES

- PRIOR TO SUBMITTING A BID, THE CONTRACTOR SHALL FAMILIARIZE HIMSELF/HERSELF WITH THE SCOPE OF WORK AND ALL CONDITIONS AFFECTING THE NEW PROJECT.
- CONTRACTOR SHALL VERIFY ALL FIELD CONDITIONS AND DIMENSIONS OF THE JOB SITE AND CONFIRM THAT WORK AS INDICATED ON THESE CONSTRUCTION DOCUMENTS CAN BE ACCOMPLISHED AS SHOWN PRIOR TO COMMENCEMENT OF ANY WORK.
- ALL FIELD MODIFICATIONS BEFORE, DURING OR AFTER CONSTRUCTION SHALL BE APPROVED IN WRITING BY AN EXTENET SYSTEMS REPRESENTATIVE.
- INSTALL ALL EQUIPMENT AND MATERIALS PER THE MANUFACTURER'S RECOMMENDATIONS, UNLESS INDICATED OTHERWISE.
- NOTIFY EXTENET SYSTEMS, IN WRITING, OF ANY MAJOR DISCREPANCIES REGARDING THE CONTRACT DOCUMENTS, EXISTING CONDITIONS, AND DESIGN INTENT. THE CONTRACTOR SHALL BE RESPONSIBLE FOR OBTAINING CLARIFICATIONS FROM AN EXTENET SYSTEMS REPRESENTATIVE, AND ADJUSTING THE BID ACCORDINGLY.
- CONTRACTOR SHALL BE SOLELY RESPONSIBLE FOR ALL CONSTRUCTION MEANS, METHODS, TECHNIQUES, SEQUENCES AND PROCEDURES OF THE WORK UNDER THE CONTRACT.
- CONTRACTOR SHALL PROTECT ALL EXISTING IMPROVEMENTS AND FINISHES THAT ARE TO REMAIN. CONTRACTOR SHALL REPAIR ANY DAMAGE THAT MAY OCCUR DURING THE CONSTRUCTION TO THE SATISFACTION OF AN EXTENET SYSTEMS REPRESENTATIVE.
- CONTRACTOR PLANS TO ILLUSTRATE THE AS-BUILT CONDITION OF THE SITE, FOLLOWING THE FINAL INSPECTION BY EXTENET OR SPRINT. THE CONTRACTOR SHALL PROVIDE EXTENET SYSTEMS WITH ONE COPY OF ALL RED-LINED DRAWINGS.
- VERIFY ALL FINAL EQUIPMENT WITH AN EXTENET SYSTEMS REPRESENTATIVE. ALL EQUIPMENT LAYOUT, SPECS, PERFORMANCE INSTALLATION AND THEIR FINAL LOCATION ARE TO BE APPROVED BY EXTENET SYSTEMS. THE CONTRACTOR SHALL BE RESPONSIBLE FOR COORDINATING HIS/HER WORK WITH THE WORK AND CLEARANCES REQUIRED BY OTHERS RELATED TO SAID INSTALLATIONS.



INTERNAL REVIEW	
CONSTRUCTION SIGNATURE	DATE
RF SIGNATURE	DATE
REAL ESTATE SIGNATURE	DATE

NEXIUS
TRANSFORM YOUR BUSINESS...THROUGH WIRELESS

A/E OFFICE:
7A LYBERTY WAY
WESTFORD, MA 01886
1 (972) 755-1882

THESE DRAWINGS ARE COPYRIGHTED AND ARE THE PROPERTY OF NEXIUS SOLUTIONS, INC. AND PRODUCED SOLELY FOR THE USE OF OUR CLIENT. ANY REPRODUCTION OR USE OF THE INFORMATION CONTAINED WITHIN SAID DRAWINGS IS PROHIBITED WITHOUT WRITTEN CONSENT BY NEXIUS SOLUTIONS, INC.

EXTENET ID:	DRAWN BY:	CHECKED BY:
51166	JK	CD

REV	DATE	DESCRIPTION
A	09/11/18	ZDR90 FOR REVIEW

IT IS A VIOLATION OF THE LAW FOR ANY PERSON UNLESS THEY ARE ACTING UNDER THE DIRECTION OF A LICENSED PROFESSIONAL ENGINEER, TO ALTER THIS DOCUMENT

EXTENET SYSTEMS (CA) LLC
2000 CROW CANYON PLACE
SUITE 210
SAN RAMON, CA 94583

SITE ADDRESS
ADJACENT TO (IN PROW)
1607 CHURCH ST
OAKLAND, CA 94621

SHEET TITLE
TITLE SHEET

SHEET NUMBER
T-1

SHEET INDEX

SHEET #	SHEET TITLE	ASSOCIATED FILES, DOCUMENTS & APPLICATIONS
T-1	TITLE SHEET	WINDLOAD FILE N/A
A-1	SITE PLANS & SITE PHOTO	JPA APPLICATION N/A
A-2	POLE ELEVATIONS	PGE APPLICATION N/A
RF-1	RF DETAILS	PGE SLA N/A
EQ-1	EQUIPMENT DETAILS	MUNICIPAL PERMIT N/A
EQ-2	EQUIPMENT DETAILS	ELEC INSPECTION N/A
		EXTENET CONTACT (NOD) 866-892-5327 noc@extenetsystems.com
		CUSTOMER CONTACT N/A
		FIBER CONST PKG. N/A

PROJECT INFORMATION

<p>POLE OWNER</p> <p>COMPANY: EXTENET JOINT POLE OWNERSHIP CONTACT: LINDA MCLEAN ADDRESS: 2000 CROW CANYON PLACE SUITE 210 SAN RAMON, CA 94583 EMAIL: LMCLEAN@EXTENETSYSTEMS.COM</p>		<p>ENGINEER</p> <p>COMPANY: NEXIUS SOLUTIONS, INC. ADDRESS: 7A LYBERTY WAY WESTFORD, MA 01886 PHONE: (972) 775-1882</p>	
<p>CONTACTS</p> <p>PROJECT MANAGER COMPANY: EXTENET SYSTEMS, LLC CONTACT: AUDREY DOUGLAS ADDRESS: 2000 CROW CANYON PLACE, SUITE 210 SAN RAMON, CA 94583 EMAIL: adouglas@extenetsystems.com</p> <p>APPLICANT COMPANY: COMPANY: EXTENET SYSTEMS, LLC CONTACT: CRISTOBAL VILLEGAS ADDRESS: 2000 CROW CANYON PLACE, SUITE 210 SAN RAMON, CA 94583 EMAIL: cvillegas@extenetsystems.com</p> <p>SITE ACQUISITION COMPANY: COMPANY: NEXIUS SOLUTIONS, INC. CONTACT: CYNTHIA MACDERMOTT ADDRESS: 2595 NORTH DALLAS PARKWAY, SUITE 300 FRISCO, TX 75034 EMAIL: cynthia.macdermott@nexus.com</p>		<p>PROJECT DATA</p> <p>LATITUDE: 37.762394° LONGITUDE: -122.188591° POLE #: NOT VISIBLE COUNTY: ALAMEDA COUNTY ZONING JURISDICTION: CITY OF OAKLAND ZONING DISTRICT: RD-1 NEAREST APN: 39-3251-31 OCCUPANCY: U, UNMANNED CONSTRUCTION TYPE: ATTACHMENTS TO A EXISTING WOOD POLE TITLE 24 REQUIREMENTS: FACILITY IS UNMANNED AND NOT FOR HUMAN HABITATION. THIS PROJECT IS EXEMPT</p>	

NG 11"x17" PLOT, DRAWINGS WILL BE HALF SCALE

DR SHALL VERIFY ALL PLANS & EXISTING DIMENSIONS & CONDITIONS ON & SHALL IMMEDIATELY NOTIFY THE ENGINEER IN WRITING OF ANY BEFORE PROCEEDING WITH THE WORK OR BE RESPONSIBLE FOR SAME



Attachment D

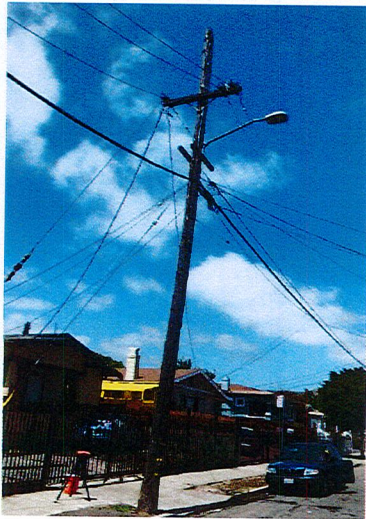

SITE PHOTO

SCALE: N.T.S.

1

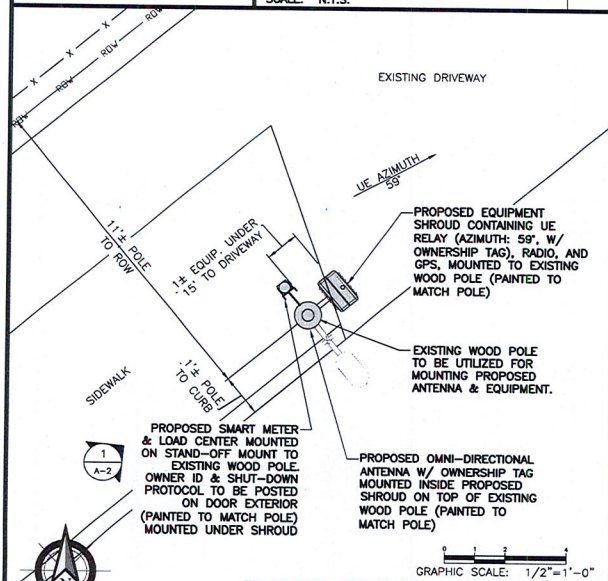

ENLARGED SITE PLAN

SCALE: 1/2" = 1'-0"

2

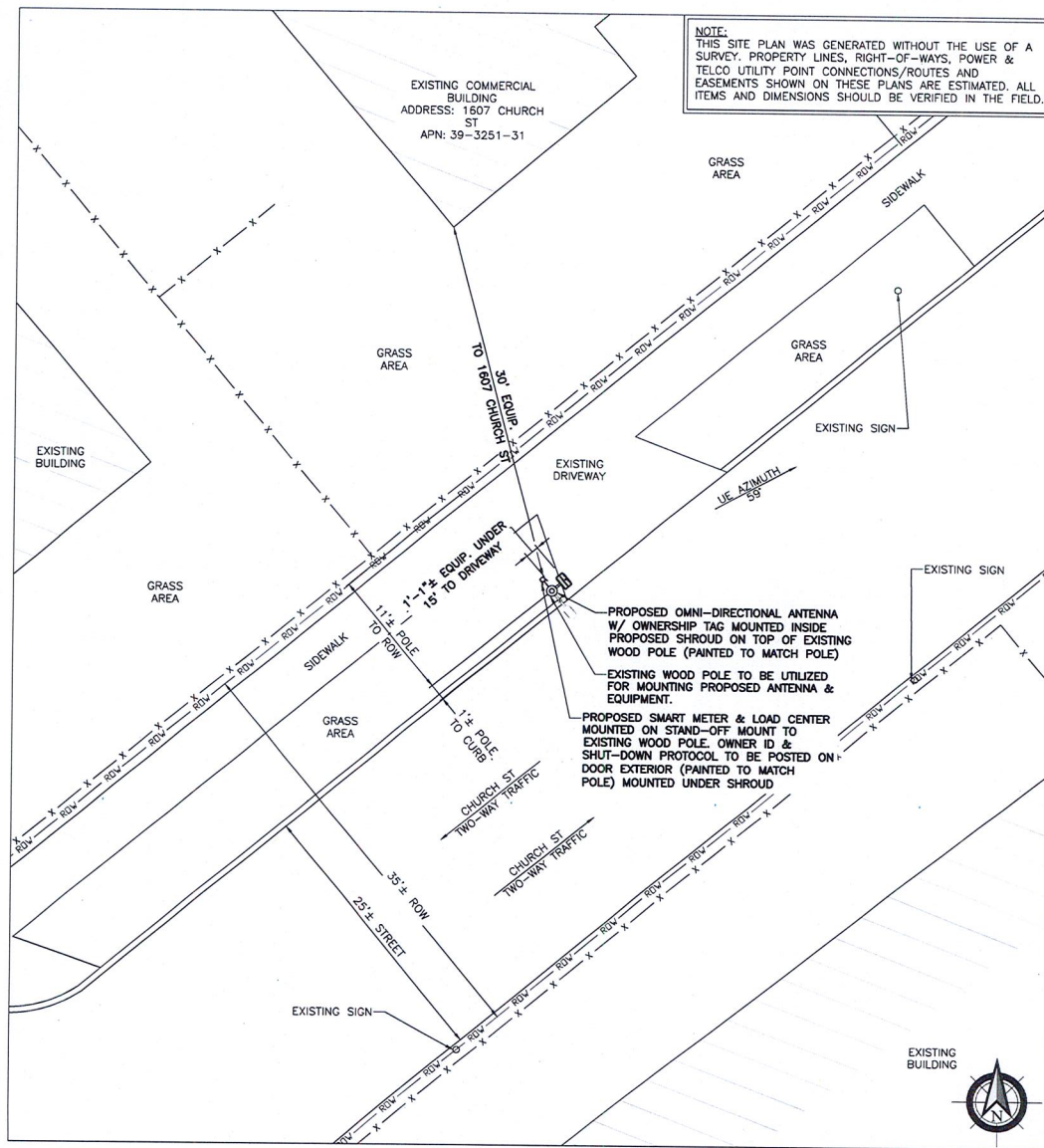

NOTE:
THIS SITE PLAN WAS GENERATED WITHOUT THE USE OF A SURVEY. PROPERTY LINES, RIGHT-OF-WAYS, POWER & TELCO UTILITY POINT CONNECTIONS/ROUTES AND EASEMENTS SHOWN ON THESE PLANS ARE ESTIMATED. ALL ITEMS AND DIMENSIONS SHOULD BE VERIFIED IN THE FIELD.

SITE PLAN

SCALE: 1:5

3



INTERNAL REVIEW

CONSTRUCTION SIGNATURE	DATE
RF SIGNATURE	DATE
REAL ESTATE SIGNATURE	DATE



A&E OFFICE
7A LYBERTY WAY
WESTFORD, MA 01886
1 (978) 755-1882

THESE DRAWINGS ARE COPYRIGHTED AND ARE THE PROPERTY OF NEXIUS SOLUTIONS, INC. AND PRODUCED SOLELY FOR THE USE OF OUR CLIENT. ANY REPRODUCTION OR USE OF THE INFORMATION CONTAINED WITHIN SAID DRAWINGS IS PROHIBITED WITHOUT WRITTEN CONSENT BY NEXIUS SOLUTIONS, INC.

EXTENET ID	DRAWN BY	CHECKED BY
51166	JK	CD

REV	DATE	DESCRIPTION
A	09/11/18	ZD90 FOR REVIEW

FIRM REGISTERED IN CA
IT IS A VIOLATION OF THE LAW FOR ANY PERSON, UNLESS THEY ARE ACTING UNDER THE DIRECTION OF A LICENSED PROFESSIONAL ENGINEER, TO ALTER THIS DOCUMENT

EXTENET SYSTEMS (CA) LLC
200 CROW CANYON PLACE
SUITE 210
SAN RAMON, CA 94583

SITE ADDRESS
ADJACENT TO (IN PROW)
1607 CHURCH ST
OAKLAND, CA 94621

SHEET TITLE
OVERALL SITE PLAN

SHEET NUMBER
A-1



INTERNAL REVIEW	
CONSTRUCTION SIGNATURE	DATE
RF SIGNATURE	DATE
REAL ESTATE SIGNATURE	DATE

NEXIUS
TRANSFORM YOUR BUSINESS... THROUGH WIRELESS

A&E OFFICE:
7A LIBERTY WAY
WESTFORD, MA 01886
1 (972) 755-1882

THESE DRAWINGS ARE COPYRIGHTED AND ARE THE PROPERTY OF NEXIUS SOLUTIONS, INC. AND PRODUCED SOLELY FOR THE USE OF OUR CLIENT. ANY REPRODUCTION OR USE OF THE INFORMATION CONTAINED WITHIN SAID DRAWINGS IS PROHIBITED WITHOUT WRITTEN CONSENT BY NEXIUS SOLUTIONS, INC.

EXTENET ID	DRAWN BY	CHECKED BY
51166	JK	CD

REV	DATE	DESCRIPTION
A	08/11/18	ZDR0 FOR REVIEW

FIRM REGISTERED IN CA
IT IS A VIOLATION OF THE LAW FOR ANY PERSON, UNLESS THEY ARE ACTING UNDER THE DIRECTION OF A LICENSED PROFESSIONAL ENGINEER, TO ALTER THIS DOCUMENT

EXTENET SYSTEMS (CA) LLC
2000 CROW CANYON PLACE
SUITE 210
SAN RAMON, CA 94583

SITE ADDRESS
ADJACENT TO (IN PROW)
1607 CHURCH ST
OAKLAND, CA 94621

SHEET TITLE
POLE ELEVATIONS

SHEET NUMBER
A-2

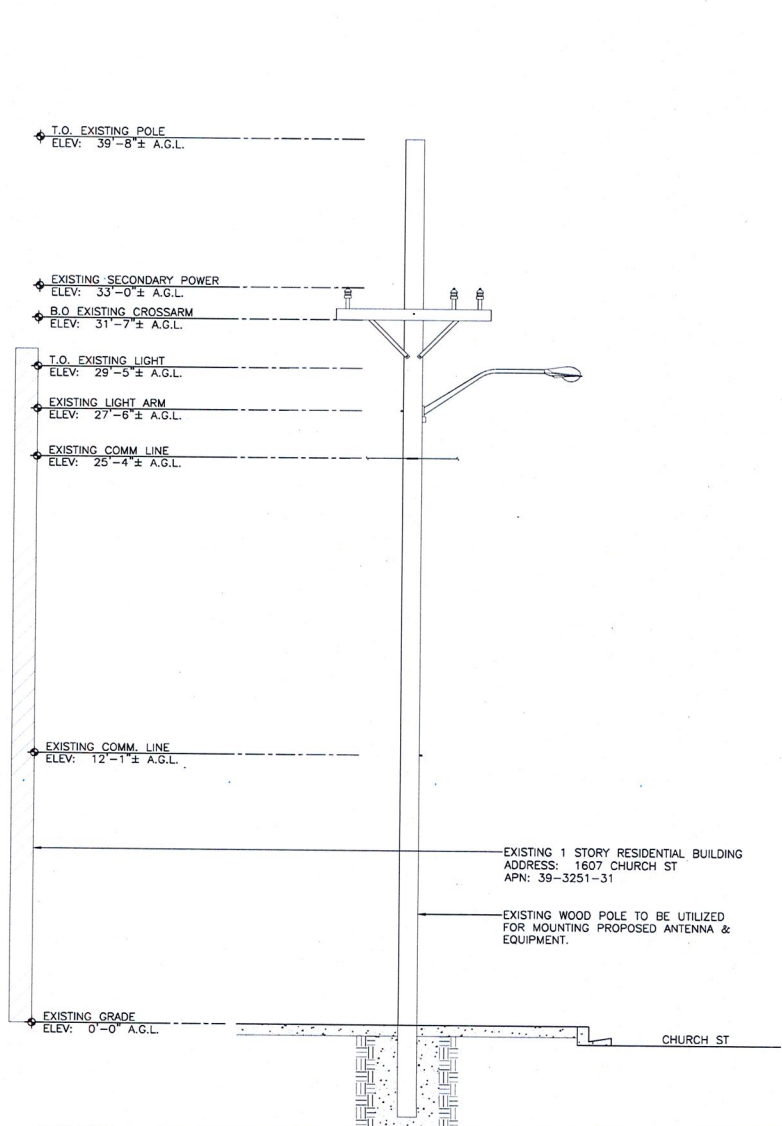

DETAIL A: EXISTING SIDE VIEW LOOKING NORTHEAST

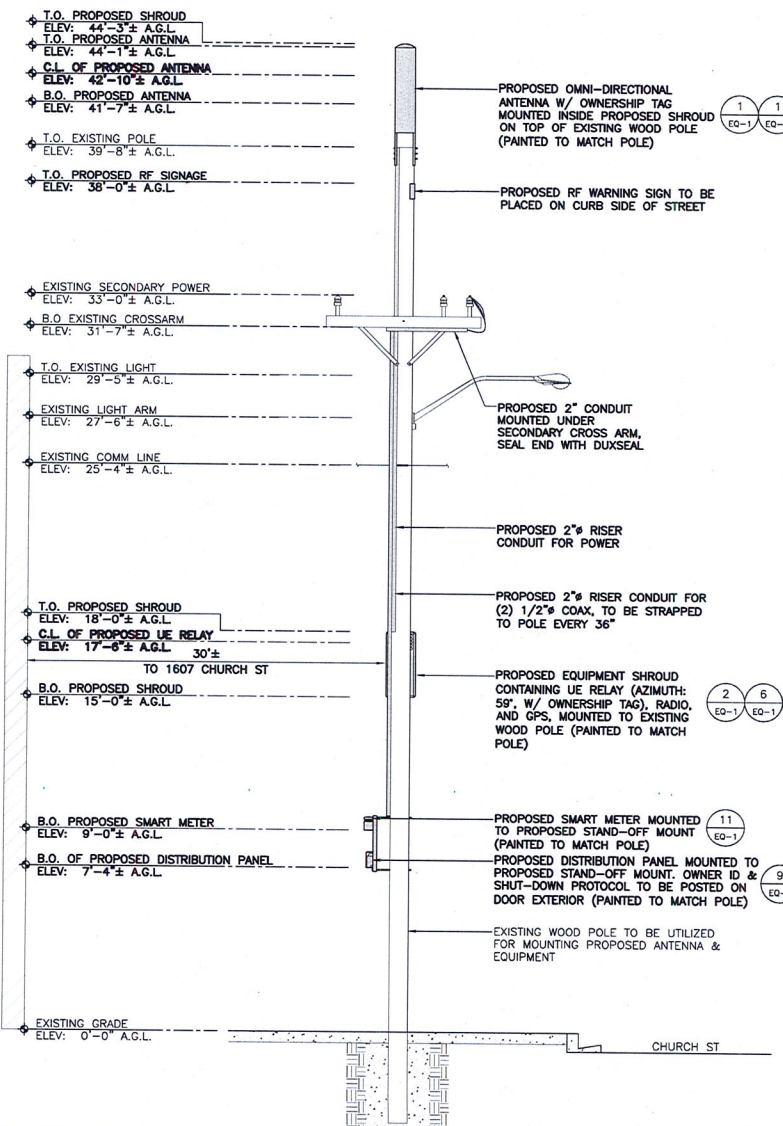

DETAIL B: PROPOSED SIDE VIEW LOOKING NORTHEAST

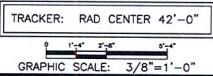

POLE ELEVATIONS
SCALE: 3/8" = 1'-0"

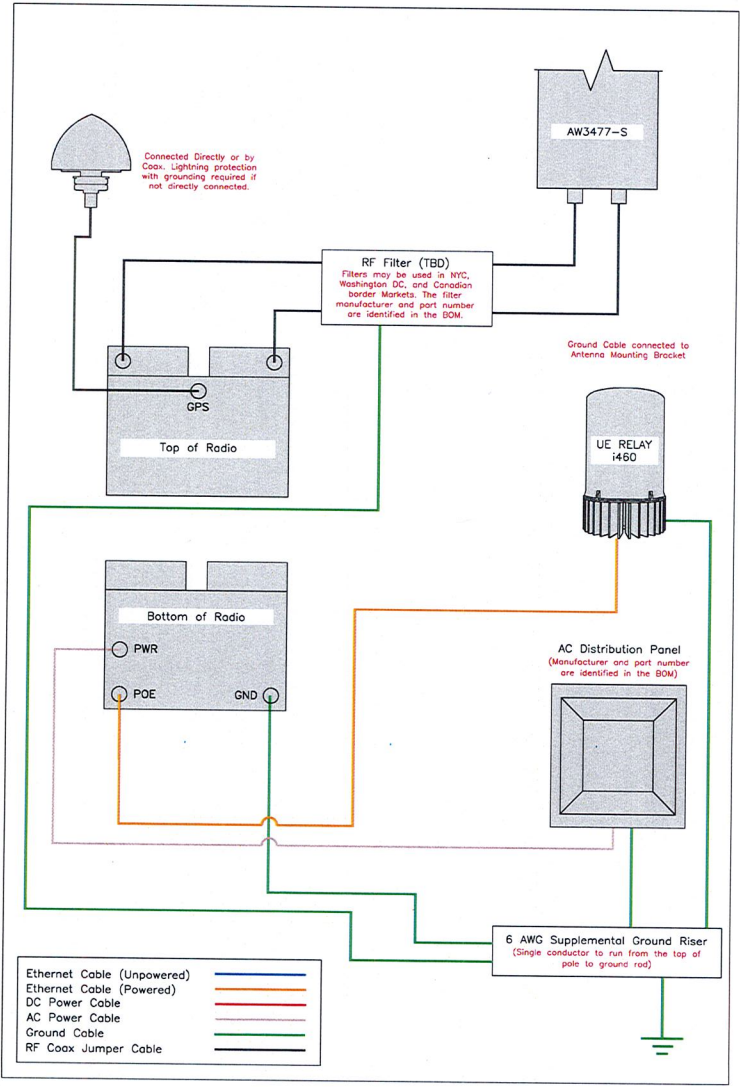

PLUMBING DIAGRAM
SCALE: N.T.S.

1

NOT USED
SCALE: N.T.S.

2

NOT USED
SCALE: N.T.S.

3



INTERNAL REVIEW	
CONSTRUCTION SIGNATURE	DATE
RF SIGNATURE	DATE
REAL ESTATE SIGNATURE	DATE

NEXIUS
TRANSFORM YOUR BUSINESS...THROUGH WIRELESS

ARE OFFICE:
7A LIBERTY WAY
WESTFORD, MA 01886
1 (978) 755-3882

THESE DRAWINGS ARE COPYRIGHTED AND ARE THE PROPERTY OF NEXIUS SOLUTIONS, INC. AND PRODUCED SOLELY FOR THE USE OF OUR CLIENT. ANY REPRODUCTION OR USE OF THE INFORMATION CONTAINED WITHIN CAD DRAWINGS IS PROHIBITED WITHOUT WRITTEN CONSENT BY NEXIUS SOLUTIONS, INC.

EXTENET ID	DRAWN BY	CHECKED BY
51166	JK	CD

REV	DATE	DESCRIPTION
A	09/11/18	ZDR9 FOR REVIEW

FIRM REGISTERED IN CA
IT IS A VIOLATION OF THE LAW FOR ANY PERSON, UNLESS THEY ARE ACTING UNDER THE DIRECTION OF A LICENSED PROFESSIONAL ENGINEER, TO ALTER THIS DOCUMENT

EXTENET SYSTEMS (CA) LLC
2000 CROW CANYON PLACE
SUITE 210
SAN RAMON, CA 94583

SITE ADDRESS
ADJACENT TO (IN PROW)
1607 CHURCH ST
OAKLAND, CA 94621

SHEET TITLE
RF DETAILS

SHEET NUMBER
RF-1

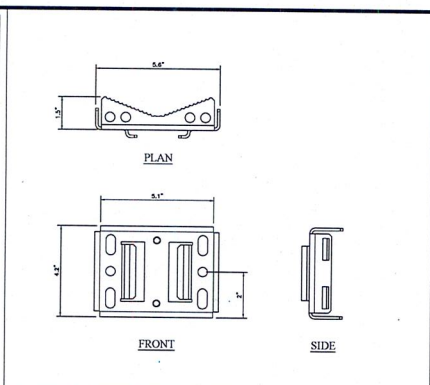
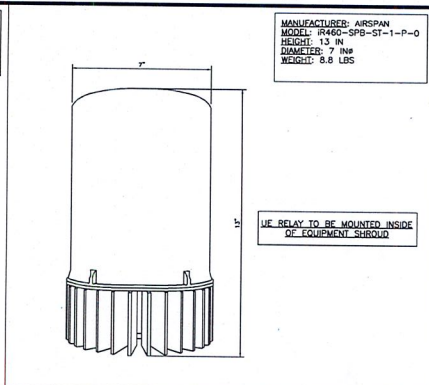
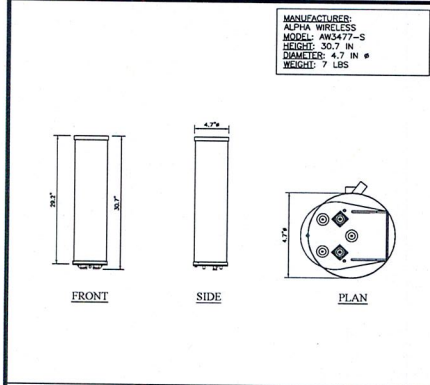

INTERNAL REVIEW

CONSTRUCTION SIGNATURE DATE

RF SIGNATURE DATE

REAL ESTATE SIGNATURE DATE

NEXIUS
TRANSFORM YOUR BUSINESS...THROUGH WIRELESS

ARE OFFICE:
7A LYBERTY WAY
WESTFORD, MA 01886
1 (978) 755-3882

THESE DRAWINGS ARE COPYRIGHTED AND ARE THE PROPERTY OF NEXIUS SOLUTIONS, INC. AND PRODUCED SOLELY FOR THE USE OF OUR CLIENT. ANY REPRODUCTION OR USE OF THE INFORMATION CONTAINED WITHIN CAD DRAWINGS IS PROHIBITED WITHOUT WRITTEN CONSENT BY NEXIUS SOLUTIONS, INC.

EXTENET ID:	DRAWN BY:	CHECKED BY:
51166	JK	CD

REV	DATE	DESCRIPTION
A	05/11/18	Z090 FOR REVIEW

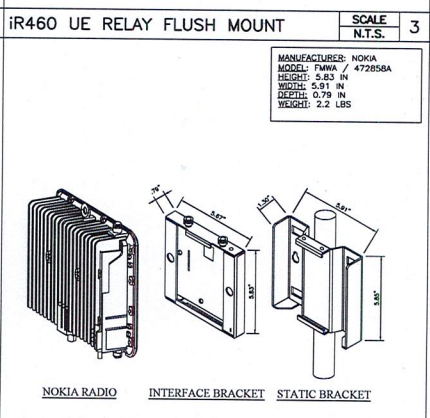
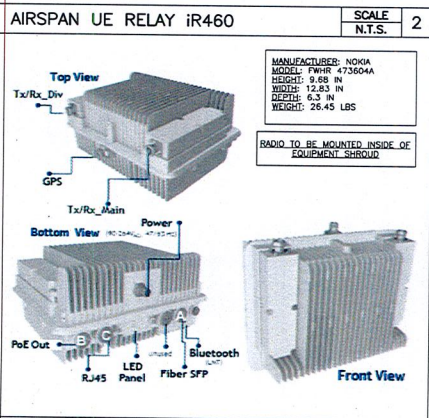
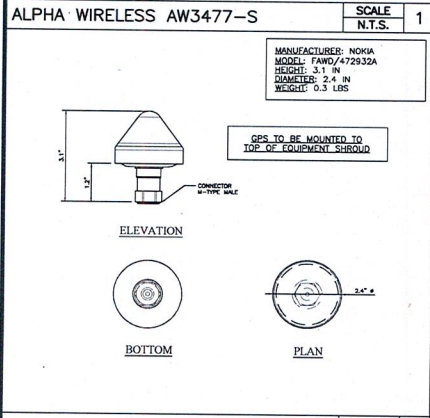

SCALE N.T.S. 4

NOT USED

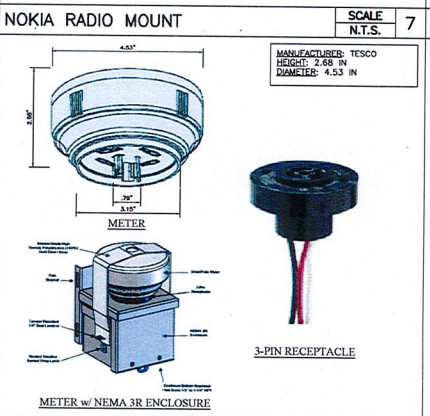
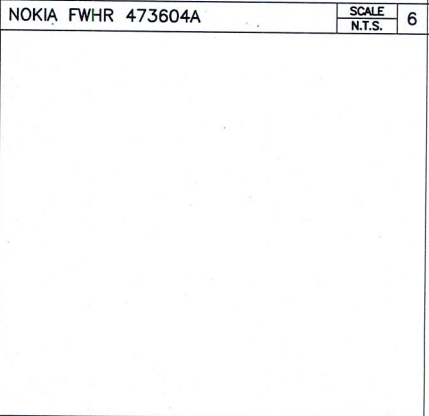
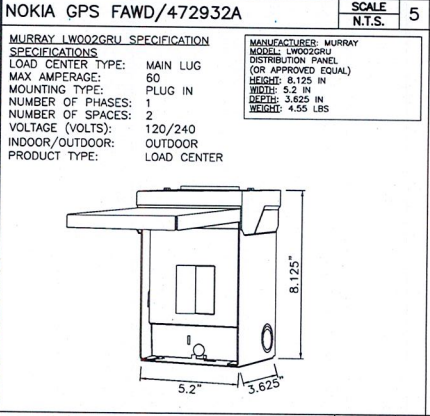

SCALE N.T.S. 8

NOT USED

CAUTION

Beyond this point Radio frequency fields at this site may exceed FCC rules for human exposure. For your safety, obey all posted signs and site guidelines for working in radio frequency environments. Workers shall maintain a minimum approach distance of 16 inches.

SITE ID: NW-CA-SANFRMNC-51166
EXTENET SYSTEMS: 1-888-492-0327

NOTICE

Radio frequency fields beyond this point may exceed the FCC general public exposure limit. Obey all posted signs and site guidelines for working in radio frequency environments. Workers shall maintain a minimum approach distance of 16 inches.

SITE ID: NW-CA-SANFRMNC-51166
EXTENET SYSTEMS: 1-888-492-0327

ANTENNA SIGNAGE

- EXTENET TO INSTALL SIGNS PER 6095 FULE 94.5 APPENDIX H, EXHIBIT A: AT NODE/ANTENNA POLE.
- SPECIFIC EMC PLACARD WILL BE PLACED AFTER EMC REPORT.
- ON WOOD POLES: SIGN ON ALUMINUM WITH SS SCREW TO THE POLE.
- ON METAL POLES: ADHESIVE VINYL OR PLACARD STRAPPED WITH SS TIES.
- ON CONCRETE/COMPOSITE: PLACARD STRAPPED WITH SS TIES.
- SIGN PLACEMENT: AFFIX TO THE STRUCTURE 3-4" BELOW THE COMMERCIAL RF ANTENNA(S) ON CURB SIDE.
- SIZE: APPROX. 8"x5".

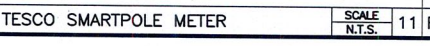

SCALE N.T.S. 12

RF SIGNAGE

extenet
SYSTEMS

INTERNAL REVIEW

CONSTRUCTION SIGNATURE DATE

RF SIGNATURE DATE

REAL ESTATE SIGNATURE DATE

NEXIUS
TRANSFORM YOUR BUSINESS...THROUGH WIRELESS

ARE OFFICE:
7A LYBERTY WAY
WESTFORD, MA 01886
1 (978) 755-3882

THESE DRAWINGS ARE COPYRIGHTED AND ARE THE PROPERTY OF NEXIUS SOLUTIONS, INC. AND PRODUCED SOLELY FOR THE USE OF OUR CLIENT. ANY REPRODUCTION OR USE OF THE INFORMATION CONTAINED WITHIN CAD DRAWINGS IS PROHIBITED WITHOUT WRITTEN CONSENT BY NEXIUS SOLUTIONS, INC.

EXTENET ID:	DRAWN BY:	CHECKED BY:
51166	JK	CD

REV	DATE	DESCRIPTION
A	05/11/18	Z090 FOR REVIEW

FIRM REGISTERED IN CA

IT IS A VIOLATION OF THE LAW FOR ANY PERSON UNLESS THEY ARE ACTING UNDER THE DIRECTION OF A LICENSED PROFESSIONAL ENGINEER, TO ALTER THIS DOCUMENT

EXTENET SYSTEMS (CA) LLC
2009 CROW CANYON PLACE
SUITE 210
SAN RAMON, CA 94583

SITE ADDRESS
ADJACENT TO (IN PROW)
1607 CHURCH ST
OAKLAND, CA 94621

SHEET TITLE
EQUIPMENT DETAILS

SHEET NUMBER
EQ-1

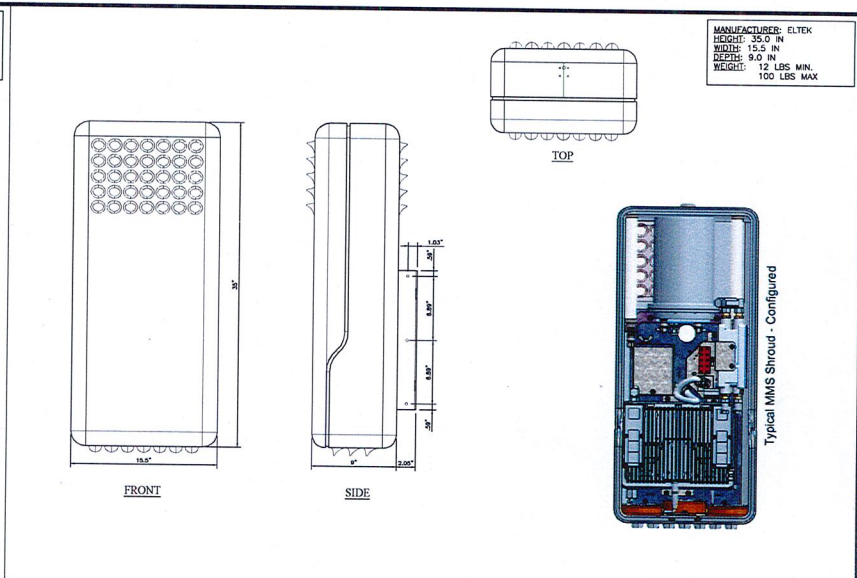
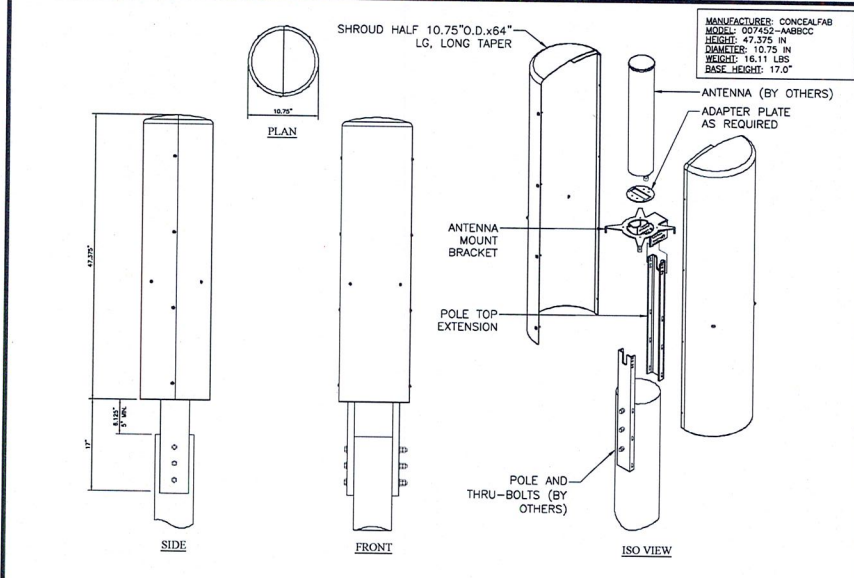

ANTENNA SHROUD DETAIL

SCALE
N.T.S.

1

ELTEK MMS EQUIPMENT SHROUD

SCALE
N.T.S.

2

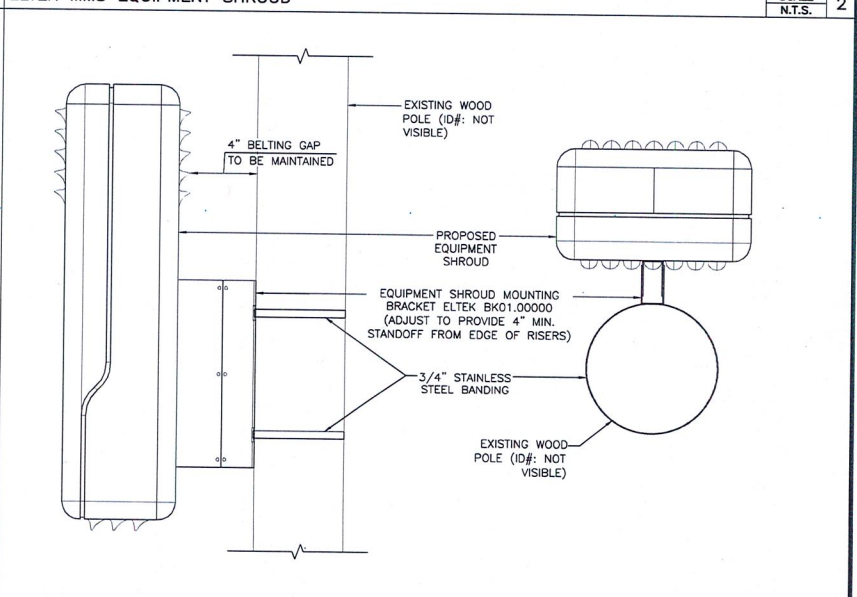
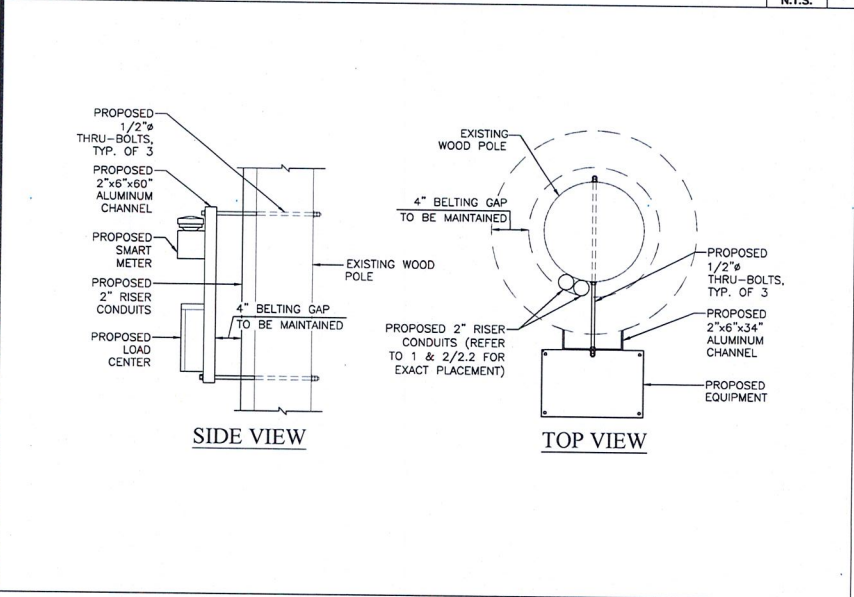

METER & LOAD CENTER MOUNTING DETAIL

SCALE
N.T.S.

3

EQUIPMENT SHROUD MOUNTING DETAIL

SCALE
N.T.S.

4



INTERNAL REVIEW	
CONSTRUCTION SIGNATURE	DATE
RF SIGNATURE	DATE
REAL ESTATE SIGNATURE	DATE

NEXIUS
 TRANSFORM YOUR BUSINESS. THROUGH WIRELESS

AVE OFFICE:
 7A LIBERTY WAY
 WESTFORD, MA 01886
 1 (972) 755-1882

THESE DRAWINGS ARE COPYRIGHTED AND ARE THE PROPERTY OF NEXIUS SOLUTIONS, INC. AND PRODUCED SOLELY FOR THE USE OF OUR CLIENT. ANY REPRODUCTION OR USE OF THE INFORMATION CONTAINED WITHIN SAID DRAWINGS IS PROHIBITED WITHOUT WRITTEN CONSENT BY NEXIUS SOLUTIONS, INC.

EXTENET ID	DRAWN BY	CHECKED BY
51166	JK	CD

REV	DATE	DESCRIPTION
A	08/11/18	Z090 FOR REVIEW

FIRM REGISTERED IN CA

IT IS A VIOLATION OF THE LAW FOR ANY PERSON UNLESS THEY ARE ACTING UNDER THE DIRECTION OF A LICENSED PROFESSIONAL ENGINEER, TO ALTER THIS DOCUMENT

EXTENET SYSTEMS (CA) LLC
 2000 CROW CANYON PLACE
 SUITE 210
 SAN RAMON, CA 94583

SITE ADDRESS
 ADJACENT TO (IN PROW)
 1607 CHURCH ST
 OAKLAND, CA 94621

SHEET TITLE
EQUIPMENT DETAILS

SHEET NUMBER
EQ-2



LOCATION

Address: 1607 CHURCH ST OAKLAND, CA 94621

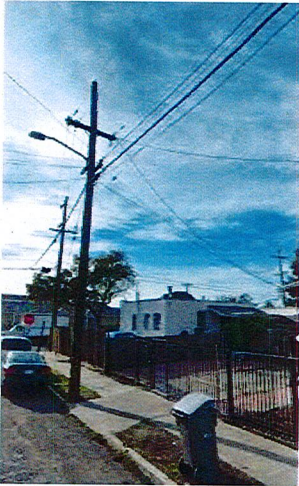

EXISTING



PROPOSED - SOUTH WEST

extenet[®]
mConnectivity
SYSTEMS Everywhere
2000 Crow Canyon Place, Suite 210 San Ramon, CA 94583

Photo Simulation
Site: NW-CA-SANFRNMC-51166
SF90XS1N7-M

Disclaimer: These photographic simulations have been provided to aid in visualizing how the proposed wireless telecommunications facility shown herein would appear if constructed. While these renderings are not an exact science, they have been prepared diligently to accurately reflect dimensions, scale, depth, coloring, texture, and other important elements in the proposed design insofar as the digital medium allows. Taken together with the engineering drawings and other materials submitted with the application, they are fair and reasonable visual depictions of how the proposed site would appear.





LOCATION

Address: 1607 CHURCH ST OAKLAND, CA 94621



EXISTING



PROPOSED - SOUTH WEST

extenet[®]
mConnectivity
SYSTEMS
Everywhere
2000 Crow Canyon Place, Suite 210 San Ramon, CA 94583

Photo Simulation
Site: NW-CA-SANFRNMC-51166
SF90XS1N7-M

Disclaimer: These photographic simulations have been provided to aid in visualizing how the proposed wireless telecommunications facility shown herein would appear if constructed. While these renderings are not an exact science, they have been prepared diligently to accurately reflect dimensions, scale, depth, coloring, texture, and other important elements in the proposed design insofar as the digital medium allows. Taken together with the engineering drawings and other materials submitted with the application, they are fair and reasonable visual depictions of how the proposed site would appear.

ATA
DEVELOPMENT, INC.

Alternative Site Analysis

Extenet Site Name: SF90XS1N7

Site Address: Near 1607 Church Street, Oakland, CA 94609

Preferred Candidate:



Alternate #1: Coordinates: 37°45'43.46"N, 122°11'18.66"W

Reason not suitable for wireless site: Pole does not meet GO95 standards.



Alternate #2: Coordinates: 37°45'44.43"N, 122°11'19.58"W

Reason not suitable for wireless site: Pole does not meet GO95 standards.



Radio Frequency – Electromagnetic Energy (RF-EME) Compliance Report

Site No. NW-CA-SANFRNMC- 51166
SF90XSIN7
1607 Church St
Oakland, California 94621
Alameda County
37.762394; -122.188591 NAD83
Utility Pole

EBI Project No. 6218006820
October 23, 2018

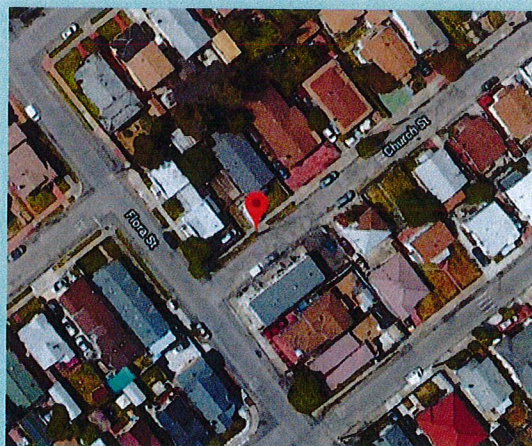

Prepared for:

ExteNet
3030 Warrenville Road, Suite 340
Lisle, IL 60532

Prepared by:



EXECUTIVE SUMMARY

Purpose of Report

EnviroBusiness Inc. (dba EBI Consulting) has been contracted by ExteNet to conduct radio frequency electromagnetic (RF-EME) modeling for ExteNet Site NW-CA-SANFRNMC- 51166 (Sprint Site SF90XSIN7) located at 1607 Church St in Oakland, California to determine RF-EME exposure levels from proposed wireless communications equipment at this site. As described in greater detail in Appendix A of this report, the Federal Communications Commission (FCC) has developed Maximum Permissible Exposure (MPE) Limits for general public exposures and occupational exposures. This report summarizes the results of RF-EME modeling in relation to relevant FCC RF-EME compliance standards for limiting human exposure to RF-EME fields.

This report contains a detailed summary of the RF EME analysis for the site.

This document addresses the compliance of proposed transmitting facilities independently at the site.

Modeling results included in this report are based on drawings dated September 11, 2018 as provided to EBI Consulting. Subsequent changes to the drawings or site design may yield changes in the MPE levels or FCC Compliance recommendations.

Maximum Permissible Exposure (MPE) Summary				
Location	% of FCC General Public/Uncontrolled Exposure Limit	% of FCC Occupational/Controlled Exposure Limit	Power Density (mW/cm²)	Occupational Approach Distance (ft)
Proposed Equipment				
Antenna Face Level	115.20	23.04	1.1520	<1' 0"
UE Relay Level	31.10	6.22	0.31100	<1' 0"
Ground	2.60	0.52	0.0260	<1' 0"
Adjacent Building	0.46	0.09	0.0046	<1' 0"

For a person anywhere at ground level, the maximum RF exposure level due to the proposed Sprint operation is calculated to be 0.0260 mW/cm², which is 2.60% of the applicable general public exposure limit. The maximum calculated level at any nearby adjacent structure is 0.46% of the general public exposure limit. The adjacent building refers to the single story building to the north of the pole.

These results are calculated based on max power assumptions for this site. The mounted antenna will contribute the majority to these emissions. Additional equipment to be installed is operating at very low power and contributions to the overall site emission is marginal. Workers accessing any equipment on this pole should follow all safety procedures outlined by the carrier and pole owners.

Statement of Compliance

Based on worst-case predictive modeling, there are no modeled exposures on any accessible rooftop or ground-level or adjacent building walking/working surface related to proposed equipment in the area that exceed the FCC's occupational and/or general public exposure limits at this site. As such, the proposed project is in compliance with FCC rules and regulations.

Signage recommendations are presented in Section 9.0 to bring the site into compliance with the FCC Rules and Regulations.

1.0 LOCATION OF ALL PROPOSED ANTENNAS AND FACILITIES AND PROPOSED RF LEVELS

ExteNet proposes the installation of one (1) Sprint wireless telecommunication antenna and one (1) UE Relay on a utility pole in Oakland, California. The proposed site will have a total of one (1) antenna and one (1) UE Relay at the site.

There are no collocated carriers on the utility pole.

2.0 LOCATION OR ALL APPROVED (BUT NOT INSTALLED) ANTENNAS AND FACILITIES AND EXPECTED RF LEVELS FROM THE APPROVED FACILITIES

There are no antennas or facilities that are approved and not installed based on information provided to EBI and ExteNet at the time of this report.

3.0 NUMBER AND TYPES OF WIRELESS TELECOMMUNICATION SITES (WTS) WITHIN 100 FEET OF THE PROPOSED SITE

Based on aerial photography review, there are no other Wireless Telecommunication Service (WTS) sites observed within 100 feet of the proposed site.

4.0 LOCATION AND NUMBER OF THE ANTENNAS AND BACK-UP FACILITIES PER STRUCTURE AND NUMBER AND LOCATION OF OTHER TELECOMMUNICATION FACILITIES ON THE PROPERTY

ExteNet proposes the installation of one (1) Sprint wireless telecommunication antenna and one (1) UE Relay on a utility pole in Oakland, California. The proposed site will have a total of one (1) antenna and one (1) UE Relay at the site.

There is one sector proposed at this site with one antenna and one UE Relay in that sector. The antenna is transmitting omnidirectionally in the 2500 Mhz Frequency range. The bottom of the antenna will be 41.6 feet above the ground level. The UE Relay will be oriented 59° from true north and transmitting in the 2500 MHz frequency range. The bottom of the UE Relay will be 17.0 feet above ground level.

There are no collocated carriers on the utility pole.

5.0 POWER RATING FOR ALL PROPOSED BACKUP EQUIPMENT SUBJECT TO THE APPLICATION

The operating power of each frequency, for modeling purposes, was assumed to be the following:

Sprint Operating Powers Per Sector		
Frequency (MHz)	Power (Watts)	# of Transmitters
Sprint Antenna 2500	20	2
Sprint UE Relay 2500	0.2	2

Additional transmitter information used in the modeling of Sprint antenna is summarized in the RoofView® export file presented in Appendix C.

6.0 TOTAL NUMBER OF WATTS PER INSTALLATION AND THE TOTAL NUMBER OF WATTS FOR ALL INSTALLATIONS ON THE STRUCTURE

The Effective Radiated Power (ERP) for each carrier and frequency is summarized below:

Effective Radiated Power (ERP) per Frequency	
Frequency (MHz)	ERP (Watts)
Sprint Antenna 2500	173
Sprint UE Relay 2500	4

7.0 PREFERRED METHOD OF ATTACHMENT OF PROPOSED ANTENNA INCLUDING DIRECTIONALITY OF ANTENNAS AND HEIGHT OF ANTENNAS ABOVE NEAREST WALKING SURFACE

Based on the information provided to EBI, the proposed antenna will be mounted to an existing utility pole and operating in the directions, frequencies, and heights mentioned in section 4.0 above.

8.0 ESTIMATED AMBIENT RADIO FREQUENCY FIELDS FOR THE PROPOSED SITE

Based on worst-case predictive modeling, there are no modeled exposures on any accessible rooftop or ground-level or adjacent building walking/working surface related to proposed equipment in the area that exceed the FCC's occupational and/or general public exposure limits at this site. As such, the proposed project is in compliance with FCC rules and regulations.

Maximum Permissible Exposure (MPE) Summary				
Location	% of FCC General Public/Uncontrolled Exposure Limit	% of FCC Occupational/Controlled Exposure Limit	Power Density (mW/cm ²)	Occupational Approach Distance (ft)
Proposed Equipment				
Antenna Face Level	115.20	23.04	1.1520	<1' 0"
UE Relay Level	31.10	6.22	0.31100	<1' 0"
Ground	2.60	0.52	0.0260	<1' 0"
Adjacent Building	0.46	0.09	0.0046	<1' 0"

It is recommended that the general public maintain a 3ft setback from the antenna. The inputs used in the modeling are summarized in the RoofView® export file presented in Appendix C.

9.0 SIGNAGE AT THE FACILITY IDENTIFYING ALL WTS EQUIPMENT AND SAFETY PRECAUTIONS FOR PEOPLE NEARING THE EQUIPMENT AS MAY BE REQUIRED BY THE APPLICABLE FCC ADOPTED STANDARDS

Signs are the primary means for control of access to areas where RF exposure levels may potentially exceed the MPE. However, it is not recommended that signage be placed in highly public areas where there are no exposures above the FCC general public limits. Signage at this site should be installed following carrier and local jurisdiction requirements. Additionally, any elevated workers should be alerted to any potential exposures at the antenna face. There are no exposures above the FCC limits at ground level and therefore barriers are not recommended.

Workers that are elevated above the rooftop and ground may be exposed to power densities greater than the applicable FCC limits. Workers should be informed via signage about the presence of antennas and their associated fields and practice RF Safety Procedures.

Access to this site is accomplished by approaching the utility pole at ground level. Access to the antenna is gained via a lift or climbing with fall protection and therefore the antenna is not considered to be accessible to the general public.

10.0 STATEMENT ON PRODUCTION OF THIS REPORT AND QUALIFICATIONS

Please see the certifications attached in Appendix B below.

11.0 LIMITATIONS

This report was prepared for the use of ExteNet. It was performed in accordance with generally accepted practices of other consultants undertaking similar studies at the same time and in the same locale under like circumstances. The conclusions provided by EBI are based solely on the information provided by the client. The observations in this report are valid on the date of the investigation. Any additional information that becomes available concerning the site should be provided to EBI so that our conclusions may be revised and modified, if necessary. This report has been prepared in accordance with Standard Conditions for Engagement and authorized proposal, both of which are integral parts of this report. No other warranty, expressed or implied, is made.

12.0 SUMMARY AND CONCLUSIONS

EBI has prepared this Radiofrequency Emissions Compliance Report for the proposed Sprint telecommunications equipment at the site located at 1607 Church St in Oakland, California.

EBI has conducted theoretical modeling to estimate the worst-case power density from proposed the Sprint antenna to document potential MPE levels at this location and ensure that site control measures are adequate to meet FCC and OSHA requirements. As presented in the preceding sections, based on worst-case predictive modeling, there are no modeled exposures on any accessible rooftop or ground-level or adjacent building walking/working surface related to proposed equipment in the area that exceed the FCC's occupational and/or general public exposure limits at this site. As such, the proposed project is in compliance with FCC rules and regulations.

Signage is recommended at the site as presented in Section 9.0. Posting of the signage brings the site into compliance with FCC rules and regulations.

Appendix A
Federal Communications
Commission (FCC) Requirements

The FCC has established Maximum Permissible Exposure (MPE) limits for human exposure to Radiofrequency Electromagnetic (RF-EME) energy fields, based on exposure limits recommended by the National Council on Radiation Protection and Measurements (NCRP) and, over a wide range of frequencies, the exposure limits developed by the Institute of Electrical and Electronics Engineers, Inc. (IEEE) and adopted by the American National Standards Institute (ANSI) to replace the 1982 ANSI guidelines. Limits for localized absorption are based on recommendations of both ANSI/IEEE and NCRP.

The FCC guidelines incorporate two separate tiers of exposure limits that are based upon occupational/controlled exposure limits (for workers) and general public/uncontrolled exposure limits for members of the general public.

Occupational/controlled exposure limits apply to situations in which persons are exposed as a consequence of their employment and in which those persons who are exposed have been made fully aware of the potential for exposure and can exercise control over their exposure. Occupational/controlled exposure limits also apply where exposure is of a transient nature as a result of incidental passage through a location where exposure levels may be above general public/uncontrolled limits (see below), as long as the exposed person has been made fully aware of the potential for exposure and can exercise control over his or her exposure by leaving the area or by some other appropriate means.

General public/uncontrolled exposure limits apply to situations in which the general public may be exposed or in which persons who are exposed as a consequence of their employment may not be made fully aware of the potential for exposure or cannot exercise control over their exposure. Therefore, members of the general public would always be considered under this category when exposure is not employment-related, for example, in the case of a telecommunications tower that exposes persons in a nearby residential area.

Table I and Figure I (below), which are included within the FCC's OET Bulletin 65, summarize the MPE limits for RF emissions. These limits are designed to provide a substantial margin of safety. They vary by frequency to take into account the different types of equipment that may be in operation at a particular facility and are "time-averaged" limits to reflect different durations resulting from controlled and uncontrolled exposures.

The FCC's MPEs are measured in terms of power (mW) over a unit surface area (cm²). Known as the power density, the FCC has established an occupational MPE of 5 milliwatts per square centimeter (mW/cm²) and an uncontrolled MPE of 1 mW/cm² for equipment operating in the 1900 MHz and 2500 MHz frequency ranges. These limits are considered protective of these populations.

Table I: Limits for Maximum Permissible Exposure (MPE)				
(A) Limits for Occupational/Controlled Exposure				
Frequency Range (MHz)	Electric Field Strength (E) (V/m)	Magnetic Field Strength (H) (A/m)	Power Density (S) (mW/cm ²)	Averaging Time [E] ² , [H] ² , or S (minutes)
0.3-3.0	614	1.63	(100)*	6
3.0-30	1842/f	4.89/f	(900/f ²)*	6
30-300	61.4	0.163	1.0	6
300-1,500	--	--	f/300	6
1,500-100,000	--	--	5	6
(B) Limits for General Public/Uncontrolled Exposure				
Frequency Range (MHz)	Electric Field Strength (E) (V/m)	Magnetic Field Strength (H) (A/m)	Power Density (S) (mW/cm ²)	Averaging Time [E] ² , [H] ² , or S (minutes)
0.3-1.34	614	1.63	(100)*	30
1.34-30	824/f	2.19/f	(180/f ²)*	30
30-300	27.5	0.073	0.2	30
300-1,500	--	--	f/1,500	30
1,500-100,000	--	--	1.0	30

f = Frequency in (MHz)

* Plane-wave equivalent power density

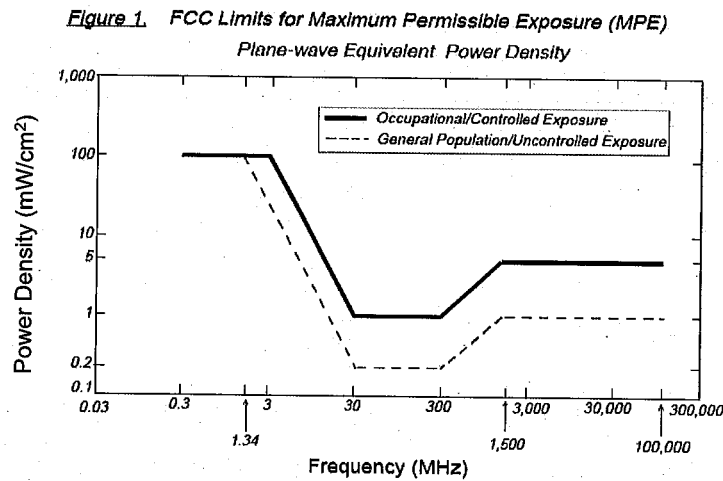

Based on the above, the most restrictive thresholds for exposures of unlimited duration to RF energy for several personal wireless services are summarized below:

Personal Wireless Service	Approximate Frequency	Occupational MPE	Public MPE
Personal Communication (PCS)	1,950 MHz	5.00 mW/cm ²	1.00 mW/cm ²
Cellular Telephone	870 MHz	2.90 mW/cm ²	0.58 mW/cm ²
Specialized Mobile Radio	855 MHz	2.85 mW/cm ²	0.57 mW/cm ²
Most Restrictive Freq. Range	30-300 MHz	1.00 mW/cm ²	0.20 mW/cm ²

MPE limits are designed to provide a substantial margin of safety. These limits apply for continuous exposures and are intended to provide a prudent margin of safety for all persons, regardless of age, gender, size, or health.

Personal Communication System (PCS) facilities used by Sprint in this area operate within a frequency range of 800-1900 MHz. Facilities typically consist of: 1) electronic transceivers (the radios or cabinets) connected to wired telephone lines; and 2) antennas that send the wireless signals created by the transceivers to be received by individual subscriber units (PCS telephones). Transceivers are typically connected to antennas by coaxial cables.

Advanced Wireless Services (AWS) facilities used by the carrier in this area operate within a frequency range of 2496 - 2690 MHz. Facilities typically consist of: 1) electronic transceivers (the radios or cabinets); and 2) antennas that send the wireless signals created by the transceivers to be received by individual subscriber units. Transceivers are typically connected to antennas by coaxial cables.

Because of the short wavelength of PCS/AWS services, the antennas require line-of-site paths for good propagation, and are typically installed above ground level. Antennas are constructed to concentrate energy towards the horizon, with as little energy as possible scattered towards the ground or the sky. This design, combined with the low power of PCS facilities, generally results in no possibility for exposure to approach Maximum Permissible Exposure (MPE) levels, with the exception of areas directly in front of the antennas.

FCC Compliance Requirement

A site is considered out of compliance with FCC regulations if there are areas that exceed the FCC exposure limits and there are no RF hazard mitigation measures in place. Any carrier which has an installation that contributes more than 5% of the applicable MPE must participate in mitigating these RF hazards.

Appendix B

Certifications

Preparer Certification

I, Ciara Middleton, state that:

- I am an employee of EnviroBusiness Inc. (d/b/a EBI Consulting), which provides RF-EME safety and compliance services to the wireless communications industry.
- I have successfully completed RF-EME safety training, and I am aware of the potential hazards from RF-EME and would be classified "occupational" under the FCC regulations.
- I am familiar with the FCC rules and regulations as well as OSHA regulations both in general and as they apply to RF-EME exposure.
- I have reviewed the data provided by the client and incorporated it into this Site Compliance Report such that the information contained in this report is true and accurate to the best of my knowledge.

Ciara Middleton

Reviewed and Approved by:

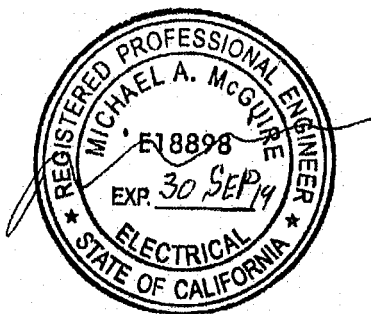

sealed 24oct2018

Michael McGuire
Electrical Engineer

Note that EBI's scope of work is limited to an evaluation of the Radio Frequency – Electromagnetic Energy (RF-EME) field generated by the antennas and broadcast equipment noted in this report. The engineering and design of the structure, as well as the impact of the antennas and broadcast equipment on the structural integrity of the structure, are specifically excluded from EBI's scope of work.

Appendix C

Roofview® Export File / Antenna Inventory

Map, Settings, Antenna, and Symbol Data Table .. Exported from workbook -> RoofView 4.15.xls
 Done on 8/14/2018 at 5:12:26 PM.
 Use this format to prepare other data sets for the RoofView workbook file.
 You may use as many rows in this TOP header as you wish.
 The critical point are the cells in COLUMN ONE that read 'Start...' (eg. StartMapDefinition)
 If used, these (4) headers are required to be spelled exactly, as one word (eg. StartMapDefinition)
 The very next row will be considered the start of that data block.
 The first row of the data block can be a header (as shown below), but this is optional.
 When building a text file for import, Add the Map info first, then the Antenna data, followed by the symbol data.
 All rows above the first marker line 'Start...' will be ignored, no matter how many there are.
 This area is for you use for documentation.
 End of help comments.

You can place as much text here as you wish as long as you don't place it below
 the Start Map Definition row below the blue line.
 You may insert more rows using the Insert menu.
 Should you need additional lines to document your project, simply insert additional rows
 by highlighting the row number adjacent to the blue line below and then clicking on the Insert menu
 and selecting rows.

StartMapDefinition

Roof Max Roof Max Map Max Map Max Y Offset X Offset Number o envelope
 170 160 180 170 10 10 1 \$U\$41:\$F>\$U\$41:\$FX\$210

StartSettingsData

Standard Method Uptime Scale Factr Low Thr Low Color Mid Thr Mid Color HI Thr HI Color Over Colo Ap Ht Mul Ap Ht Method
 4 2 3 1 100 1 500 4 5000 2 3 1.5 1

StartAntennaData It is advisable to provide an ID (ant 1) for all antennas

ID	Name	Freq (MHz)	Power	Trans Count	Coax Len	Coax Type	Other Loss	Input Power	Calc Power	Mfg	Model	X (ft)	Y (ft)	Z (ft)	Type	Aper (ft)	dBd Gain	BWdth Pt Dir	Uptime Profile	ON flag
SPT1	Sprint	2500	20	2	0	0	0	0	0	Alpha	AW3477-S	30	30	41.615		2.43	6.35 OMNI			ON•
UE1	UE Relay	2500	0.2	2	0	0	0	0	0	AirSpan	iRelay 460	30	30	16.96		1.08	9.85 35;59			ON•

StartSymbolData

Sym	Map Mark	Roof X	Roof Y	Map Labe	Description (notes for this table only)
Sym		5	35	AC Unit	Sample symbols
Sym		14	5	Roof Access	
Sym		45	5	AC Unit	
Sym		45	20	Ladder	

3B

PUBLIC NOTICE

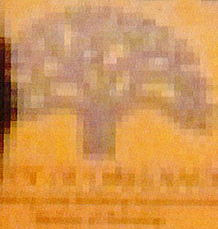

CITY OF OAKLAND

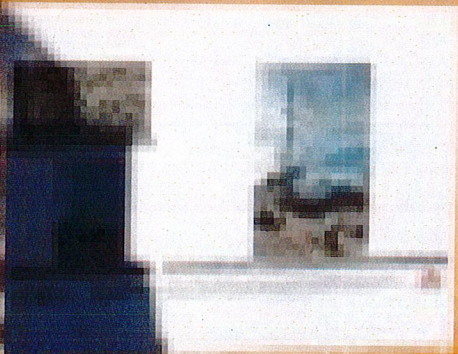

Public Notice

The City of Oakland is currently reviewing a proposed project. The project is located at [redacted] and is being reviewed by the [redacted]. The project is being reviewed by the [redacted]. The project is being reviewed by the [redacted].

PUBLIC NOTICE

CITY OF OAKLAND



CITY OF OAKLAND
OFFICE OF COMMUNITY DEVELOPMENT
1000 BROADWAY



Public Notice
[Faded text and graphics, including a yellow highlight]

Rose, Aubrey

From: Alexis or Ned Schroeder <alexisned@sbcglobal.net>
Sent: Friday, December 7, 2018 2:07 PM
To: Rose, Aubrey
Subject: December 19th Planning Commission Meeting - Agenda Items 1, 2 and 3

Hi Aubrey,

I am unable to attend the December 19th planning commission meeting where six poles will be considered for "small cell" sites. Other members of our neighborhood group will be in attendance to voice their own concerns. As the case planner, I appreciate your forwarding on my concerns to the commissioners.

Since I will not be able to review the specifications in detail due to the timing for availability,
I am voicing my opposition to this equipment on these poles strictly based on placement issues in advance of the December 19, 2018 Planning Commission meeting.

Agenda #1b: Is 5731 Bancroft PLN 18474 on the corner of the street or in front of the apartment building? If it is in front of the apartment building, this equipment will be visual clutter to all those tenants who reside there.

Agenda #2a and 2b: Is 735 E 15th Street PLN 18509 in front of an apartment building? If so, the equipment will be visual eye-sore to those tenants who reside there.

Is 3921 E 12th Street PLN 18510 at the corner of E 12th and 40th? I could not find any other pole that might up for consideration for this equipment.

Agenda #3a and 3b: The placement of equipment on both of these poles (PLNs 18506 and 18507) would constitute visual blight as it will be visible from living room windows. Also, the location on Church is a very narrow street and this would dwarf the neighborhood even further having side equipment and a pole extension and topped with a cell antenna so close to surrounding homes.

Please share my voice that says to deny these applications for the reasons stated above.

Thank you,
Alexis Schroeder
Oakmore Neighborhood Advocacy Group member

Attachment E